



2022

Local Volunteer and Donation Management Guidebook



Minnesota Department of Public
Safety
Homeland Security and
Emergency Management

CONTENTS

WELCOME and INTRODUCTION

Thank you for taking the time and effort to plan and prepare for an influx of volunteers and donations when a disaster occurs. Advance preparation will reduce challenges and increase positive outcomes.

This document provides step-by-step instructions, links, tools and other information to assist jurisdictions in developing an effective volunteer and donation management plan before a disaster occurs. Managing volunteers and donations are critical response and recovery activities. Preparations should begin before the early stages of a disaster.

The Local Volunteer and Donation Management Guidebook is divided into two sections:

- **General guidance** which features various volunteer and donation management topics
- **Appendix** that contains template forms, scripts, logs, checklists and other aids to establish the Volunteer and Donation Management functions.

CHAPTERS:

Steps to Making a Plan

ONE

Getting Started Page 2

TWO

Volunteer and Donation Coordination
Team Page 6

THREE

Public Information, Messaging and
Communications Page 9

FOUR

Donated Goods Management Page 12

FIVE

Unaffiliated Volunteer Management Page 15

APPENDIX

Attachments A through N Pages 19-89

A Note about Hyperlinks in this Document

All external links in this document have been created with meaningful text. The Uniform Resource Locator (URL) is also published to be available as a resource for individuals who would like to print the document. The URL addresses that are spelled out in the document are not active links to avoid the confusion of presenting duplicate links.

VOLUNTEER AND DONATION MANAGEMENT GUIDEBOOK

CHAPTER 1 - GETTING STARTED

Most Important Task: Form the Planning Team responsible for creating the plan to manage disaster volunteers and donated goods.

GETTING STARTED

STEP ONE – Developing a Planning Team

Begin the planning process by inviting representatives from government agencies, voluntary organizations, and the local community who have personnel, facilities, equipment or other resources to assist in managing unaffiliated volunteers or donated goods. It is important to be inclusive of socially vulnerable populations as well as all communities within the jurisdiction. The term “local” will refer to the city, county or tribal nation.

Potential team members may include a local representative from:

- City/county/tribal Volunteer Manager or Coordinator
- Public Information Officer
- Government agencies such as emergency management, public health, parks and recreation, etc.
- Representatives of VOAD (voluntary organizations) who can assist with volunteer or donated goods management
- Volunteer Center representative
- Nonprofits which may provide services
- Representative from the Extension Service or Extension Disaster Education Network (EDEN)
- The United Way “211” or other agency that might provide call center services.
- Local C.O.A.D. or community service

organizations e.g. veteran’s clubs, Elks, Lions, Rotary, etc.

- Business community representatives
- Public, private, tribal and charter schools
- Faith-based organizations

Convene meetings with the team to discuss how they may be able to contribute to the volunteer and donation management plan. Then, begin development of any executive orders, memorandum of understanding (MOU) or letter of agreement (LOA) documents necessary to formalize relationships.

Chapter two will provide additional information. Some team members may also be willing to serve as the Local VAL (Voluntary Agency Liaison) or join the Volunteer and Donation Coordination Team (VDCT) to assist when a disaster occurs.

STEP TWO – Incorporate Volunteer and Donation Management Requirements into the Plan

The structure for the Volunteer and Donation Management Plan can vary widely depending upon how the overall plan has been developed. In most cases, the plan will become an attachment or guidance document to the Logistics section or Emergency Support Function (ESF) #6 of the local all-hazard disaster plan.

No matter which format chosen for the Volunteer and Donation Management Plan, make sure it addresses volunteer and donation

management guidance contained in Minnesota State Statutes and the Local Emergency Operations Plan Crosswalk (MNWALK), Questions 9 and 10.

- MNWALK Question 9 - Identify volunteer resources in your jurisdiction:
 - Coordination of unaffiliated volunteers
 - Volunteer registration, assignment, waivers, and supervision
 - Minnesota Voluntary Organizations Active in Disaster (MNVOAD) as a volunteer resource
 - Use a safety supervisor to monitor volunteers.
 - Safety briefs for all volunteers / Equipment use / Training on activities requested for volunteers to perform.
- MNWALK Question 10 - Identify responsible agency for coordination of the functions of unsolicited donations management, include:
 - Potential donations center facilities
 - Procedures for collecting, sorting, and distributing donations
 - Procedures for donations coordination with partner agencies
 - Public information concerning donations
 - Managing unsolicited cash donations

The Federal Emergency Management Agency (FEMA) has also developed 10-point National Volunteer and Donation Management Strategies which may be useful in the planning efforts. A copy of each of these strategies can be found in [Attachment G](#) of this guidebook.

A template plan has been included at the end of this document in [Attachment N](#). The template can be adapted for the jurisdiction.

STEP THREE – Determine Planning Roles and Responsibilities

Local Government

Management of unaffiliated disaster volunteers and unsolicited donated goods are the responsibility of the local government. The local government is responsible for approving and activating their Volunteer and Donation Management Plan.

State Government

The state government provides guidance to local emergency managers about the development of plans and the formation of local volunteer and donation management teams. During times of disaster, state volunteer and donation management personnel may provide support regarding volunteer and donation management resources when local authorities are overwhelmed.

Additional volunteer or donation management assistance or resources needed during a disaster situation should be requested through Minnesota’s State Emergency Operations Center (SEOC) when it is activated or through the State Duty Officer at other times.

Federal Government

The federal government, through FEMA, provides additional volunteer and donation management resources and expertise when local and state programs are overwhelmed and all resources are exhausted. Federal assistance is requested by Minnesota Homeland Security and Emergency Management (HSEM) leadership.

STEP FOUR – Set a Schedule for Plan Development and Begin Writing the Plan

Here is a typical schedule that could be used by the planning team to create an effective Volunteer and Donation Management Plan. The local team may complete the tasks at a different pace. Please note that “council” refers

to the local governing body.

Month One

- Obtain council approval to prepare a Volunteer and Donation Management Plan
- Identify and invite members to serve on a Volunteer and Donation Planning Team

Month Two

- Conduct first planning team meeting
- Establish monthly meeting times
- Become familiar with reference materials
- Assign plan sections to team members

Month Three

- Develop and confirm organizational charts for volunteer and donation management
- Obtain status reports on other sections
- Research what ordinances or authorities already exist
- Determine if a memorandum of understanding (MOU) or a letter of agreement (LOA) will be necessary with partner agencies. If so, begin to develop the documents

Month Four

- Reach consensus on unaffiliated volunteer management information to include in the plan
- Reach consensus on unsolicited donated goods management information to include in the plan

Month Five

- Continue work on all sections of the draft plan
- Complete work on the MOU and LOA documents

Month Six

- Complete work on draft plan
- Submit draft plan, MOU and LOA documents for council review

Month Seven

- Incorporate comments from the council
- Finalize the plan, MOU and LOA documents

Month Eight

- Submit for council approval
- Receive council approval and file where appropriate
- Celebrate the approved plan!

After the Plan is Complete

Remember that it is a living document. It will go through the local approval process several times over its life. Resources and partners may change and new strategies may be developed.

To keep the plan up to date:

- Conduct regular reviews to make sure that the content of the plan is as current and complete as possible, especially after a disaster highlights areas to improve
- Develop a training schedule for plan stakeholders to increase their skills and knowledge
- Develop a schedule for exercising the plan to:
 - Determine if it will work
 - Make sure all stakeholders are aware of their responsibilities under the plan
 - Expose gaps in the plan
 - Promote familiarity between all stakeholders

RESOURCES

[Attachment G – “10 Point” National Volunteer and Donation Management Strategies \(FEMA\)](#)

[Attachment N - Template Plan: Volunteer and Donation Management Plan](#)

Lesson Learned:

“In preparing for battle, I have always found that plans are useless, but planning is indispensable.”

Dwight D. Eisenhower –
34th President of the US (1953-1961)

CHECKLIST

Chapter 1 – Getting Started

- Assemble the planning team*
- Decide on a format for the plan*
- Set a schedule for development of the Volunteer and Donation Management Plan*
- Contact the HSEM Volunteer Resources Coordinator for additional assistance if needed*

VOLUNTEER AND DONATION MANAGEMENT GUIDEBOOK

CHAPTER 2 - VOLUNTEER AND DONATION COORDINATION TEAM

Most Important Task: Appoint a Local Voluntary Agency Liaison and Team Leaders to carry out the plans that are being developed.

Managing large numbers of unaffiliated disaster volunteers and warehouses full of unsolicited donated goods is an intense undertaking for personnel and resources. This chapter discusses how to establish a Volunteer and Donation Coordination Team to effectively manage unaffiliated volunteers and unsolicited donated goods during a disaster.

VOLUNTEER AND DONATION COORDINATION TEAM

Local emergency managers should establish a Volunteer and Donation Coordination Team (VDCT), which can be led by a Local VAL (Voluntary Agency Liaison) to serve as the backbone of their volunteer and donation management efforts. The VDCT is typically formed under the Logistics function in the Local Emergency Operations Center (EOC) and scalable according to the needs.

The following organizational chart illustrates team members and their relationships to one another.

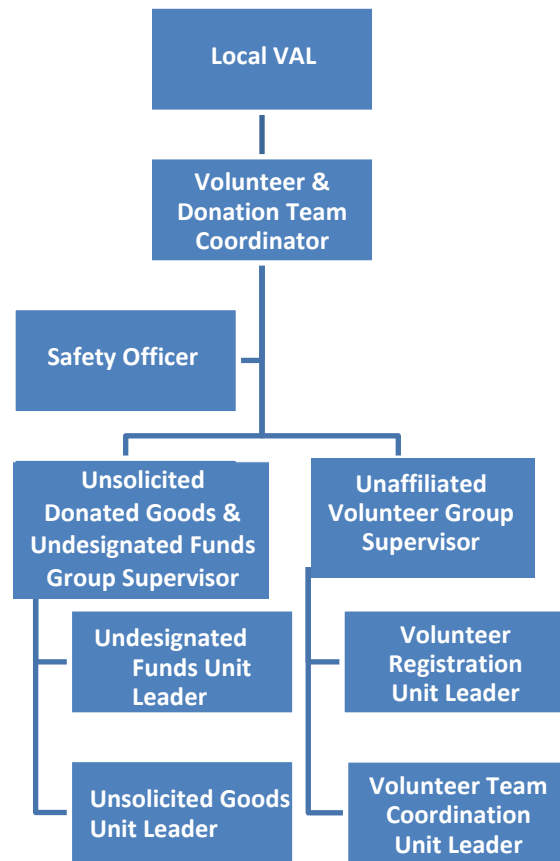

Volunteer and Donation Coordination Team Leadership

- The *Volunteer and Donation Team Coordinator* – Manages the overall unaffiliated volunteer and unsolicited donated goods management operation.
- The *Safety Officer* –Appoint a Safety Officer who can ensure that all activities are performed in the safest manner possible and that injuries that do occur are treated in the most effective way possible.

- The *Unsolicited Donated Goods and Undesignated Funds Group Supervisor* – Manages the flow of unsolicited donated goods and undesignated financial contributions to clients and disaster relief voluntary organizations. Depending on the size of the operation, additional personnel will likely be needed to handle donated goods and funds received.
- The *Unaffiliated Volunteer Group Supervisor* – Coordinates and manage the efforts of unaffiliated volunteers who offer to help in the wake of disasters or emergencies. Depending on the size of the volunteer management effort, additional personnel will likely be needed to focus on volunteer registration and to coordinate work crews in the field.

Position descriptions for volunteer and donation team leaders can be found in [Attachment A](#) of this guidebook. More information can also be located in HSEM’s Local Voluntary Agency Liaison Guidebook.

Public Information Function

While not directly a part of the VDCT, the organization’s public information staff plays an important role in volunteer and donated goods management efforts.

Volunteer and donation managers should collaborate with public information staff to develop messages about how to volunteer during the disaster, goods that are needed and not needed, financial contributions, volunteer and donation facility operations. Chapter 3 of this guidebook contains additional information about these messages.

STAFFING OTHER VOLUNTEER AND DONATION MANAGEMENT POSITIONS

Additional personnel, beyond the team leaders, will be needed to staff different stations in each

established volunteer or donation management facility. Listed below are suggestion for staffing volunteer and donation management facilities.

City/County/Tribal Personnel

Staff from one or more local government agencies may be assigned to perform volunteer or donation management duties during a disaster operation. Examples include:

- Parks and Recreation staff
- Human Services staff
- Community volunteers who are already affiliated with the City/County/Tribe such as – Community Emergency Response Team (CERT) members; Volunteers in Police Service (VIPS); Fire, Police or Sheriff Reserves or Auxiliaries; and other established volunteers. Make certain that their volunteer duties do not conflict with other disaster or public safety obligations
- Clerical personnel from other agencies
- Mutual Assistance from neighboring cities, counties or tribes that are unaffected by the disaster

If additional help from other local government agencies cannot meet the need, work with the State Emergency Operations Center (SEOC) to request assistance from Association of Minnesota Emergency Managers (AMEM) members or help from other states through the Emergency Management Assistance Compact (EMAC).

Voluntary Organizations

MNVOAD (Minnesota Voluntary Organizations Active in Disaster) is a nonprofit umbrella group which coordinates voluntary organizations that respond to disasters.

Complete a MNVOAD Assistance Request Form and submit it to the State Duty Officer when help is needed. Upon receipt of the

request, MNVOAD will activate and match available organizations to meet the needs expressed in the request. Please do not directly contact any of the MNVOAD members until after the form has been processed by MNVOAD. This will reduce duplication of communications.

These voluntary organization partners may be able to assist with volunteer and donation management functions:

- Adventist Community Services Disaster Relief - donated goods specialists
- United Way 211 - call center services
- The local Volunteer Center - volunteer recruitment

Community-Based Organizations

- Faith-based groups
- Service-connected organizations, such as Veterans of Foreign Wars (VFW), American Legion, and Vietnam Veterans of America
- Local community service groups and clubs such as Elks, Lions, and Rotary
- Alumni or special interest groups

The Business Community

- Team Depot at Home Depot and Lowes Heroes at Lowes are examples of volunteers who represent local companies and offer their services during times of disaster.
- Other local businesses may express interest in helping and would make great members for the team

LINKS

[MNVOAD \(Minnesota Voluntary Organizations Active in Disaster\)](https://www.mnvoad.org/)
<https://www.mnvoad.org/>

[United Way Programs in Minnesota](http://www.unitedwaysofminnesota.org)
www.unitedwaysofminnesota.org

RESOURCES

[Attachment A - Volunteer and Donation Leadership Position Descriptions](#)

[Attachment F - Minnesota United Way “211” Call Centers](#)

Lesson Learned:

“Coming together is a beginning, staying together is progress and working together is success.”

Henry Ford - entrepreneur

CHECKLIST

Chapter 2 – The Volunteer and Donation Management Team

- Appoint the Volunteer and Donation Coordination Team leaders*
- Identify potential staff*
- Contact the HSEM Volunteer Resources Coordinator for additional guidance if needed*

VOLUNTEER AND DONATION MANAGEMENT GUIDEBOOK

CHAPTER 3 - PUBLIC INFORMATION, MESSAGING AND COMMUNICATIONS

Most Important Task: Emphasize that giving money to voluntary organizations that assist those affected by disasters or emergencies is usually the best approach.

Donations of peoplepower, money and material goods are a vital part of emergency management. Managing them requires planning, understanding and coordination between government officials, emergency management personnel, voluntary organizations, the business community, media and the public.

Failure to address the issues of unaffiliated volunteers and unsolicited goods donations can delay response and recovery operations, creating what is often called the *second* disaster.

THE MOST IMPORTANT MESSAGE

“The best way to help people who are affected by disaster is to donate funds directly to the voluntary organizations of the donor’s choice that help people during disasters.” This could be the key phrase to communicate to the public. This option permits flexibility for the MNVOAD members (voluntary organizations) to purchase items needed for the response and support the local business community.

A list of the voluntary organizations that typically assist during disasters in Minnesota can be found on the Minnesota Voluntary Organizations Active in Disaster (MNVOAD) website.

MESSAGE TIMING

It is essential to communicate to the public about how they can be effective volunteers and donors. Many ad hoc volunteer and donation efforts start in the early stages of a disaster, often before needs are known and public safety issues prevent assistance from unaffiliated volunteers.

Work with the community’s Public Information Officer (PIO) to release volunteer and donated goods information as soon as possible after the onset of the disaster. The PIO can begin sending these messages in advance if a disaster is expected, example: spring flooding. Repeat key volunteer and donated goods messages regularly to the public through the media. Consider asking the PIO to take photos and videos of the volunteers in action.

[Attachment D](#) provides sample news releases to review. Consult with the PIO about preparing sample messages in advance.

MESSAGE MEDIA

Make use of local media outlets available to inform the public about disaster volunteer and donation opportunities with accurate and consistent messages from the PIO.

Social Media (blogs, vlogs, influencers, etc.) – Social media sites are an immediate way to communicate with the public. Social media

should be monitored closely to respond to rumors and misinformation, to learn about trending topics, and to deliver messages out about effective volunteer and donation needs.

Newsletters and Newspapers – Depending on how often they are published printed or online, newsletters and newspapers may be a good place to release time-sensitive information. They can also be used to circulate volunteer and donation preparedness information.

Radio and Television – Broadcast media can share time-sensitive information with the public including information about donation collection centers, volunteer reception centers and current information about needs, etc.

Conference calls, web meetings and teleconferences – These types of events serve as another option for communicating time-sensitive information to disaster responders, leaders and to other audiences. Information can be tailored to the audience.

Government and Voluntary Organization websites – Placing general information about volunteer and donation management in a central location may serve as a good resource for the community as long as the sites are monitored and updated regularly.

News Briefings – Offering these events allows public officials to affirm basic volunteer and donation management messages. Make sure that officials conducting briefings have accurate and timely information about the volunteer and donation operations.

Informational Flyers or Graphics – Paper products that contain written or graphical information can be posted around the community if there is a disruption of cellular phone towers, Wi-Fi networks, telephone lines and/or electricity. This method may not work for time-sensitive information.

CALL CENTERS

Offers of volunteer services and donated goods may overwhelm local Public Safety dispatch centers in the aftermath of disasters and other emergencies.

Call Centers are often activated in response to these offers, where call takers can handle inquiries about community needs and resources. This allows 911 dispatchers to concentrate on more pressing public safety issues. Determine how to provide hotlines by establishing the jurisdiction's call center or by working with an outside agency to provide call center services in advance of a disaster.

If choosing to work with an outside agency, guidebook [Attachment F](#) contains a list of United Way 211 centers which cover all of Minnesota. A memorandum of understanding between the agency and the call center may be needed to establish support requirements and expectations. It is encouraged to engage a center which can assist with language translation services to be inclusive of all Minnesotans.

Whichever call center strategy is pursued, make sure that personnel have the latest public information about the disaster situation and the needed unaffiliated volunteers and goods. Call center personnel may be considered to be the public face of the volunteer and donation management system. The information they provide to callers must be timely, accurate and verified.

RESOURCES

[Attachment D – Public Information Guidance and Sample News Releases](#)

[Attachment F – Minnesota United Way "211" Call Centers](#)

Lesson Learned:

“While natural disasters capture headlines and national attention short-term, the work of recovery and rebuilding is long-term.”

Sylvia Matthews Burwell - Secretary,
US Department of Health and Human
Services (2014-2017)

CHECKLIST

***Chapter 3 – Public Information,
Messaging and Communication***

- Develop sample media releases about disaster volunteers and donations.*
- Choose an appropriate method to communicate information about being effective volunteers or donors.*
- Establish plans for a call center for volunteer offers and donated goods or arrange for an agency to do that for the jurisdiction.*
- Contact the HSEM Volunteer Resources Coordinator for additional assistance if needed*

VOLUNTEER AND DONATION MANAGEMENT GUIDEBOOK

CHAPTER 4 - DONATED GOODS MANAGEMENT

Most Important Task: Contact the Adventist Community Services Disaster Relief for help with planning to manage donated goods.

When a disaster occurs, the public is often motivated to help by contributing money, food, clothing, furniture and other goods, materials and equipment. When properly managed, these donated goods can aid the relief effort in significant ways. On the other hand, poorly managed or unmanaged donations can interfere with disaster response and recovery in equally significant ways.

This chapter provides basic information about how to properly manage donated good. Jurisdictions should also develop partnerships with voluntary organizations that can assist with donation management and finding the facilities and resources needed to successfully manage donations. [Attachment B](#) provides facility specifications and staffing recommendations.

FACILITIES

Depending upon local needs, several different types of facilities may be established to receive, store and distribute donations. Local realtors are a great source of information when looking for donation management facilities. The Minnesota Department of Employment and Economic Development (DEED) operates a website that catalogs vacant business properties which may also be useful during the facility search. See the links section at the end of this chapter for this website.

Necessary facilities may include:

- **Collection Centers** – Where donated goods are initially received, categorized, sorted

and processed to make them ready for distribution or storage. Critically needed donated goods are sent directly from this facility to distribution centers.

- **Distribution Centers** – Where clients may obtain essential donations. Located near disaster clients but outside the disaster area. These centers are stocked directly from collection centers for critically needed supplies, and from warehouses for other goods, as needed.
- **Warehouses** – Where goods that will be needed in the future, but are not currently necessary are stored. Warehouses should not be located in the disaster area. Donations stored in the warehouse should not be issued directly to clients from the warehouse. When needed, goods are shipped from the warehouse to distribution centers to be dispersed.
- **Multi-Agency Warehouses** – Where voluntary organizations store the materials and equipment that they may need for upcoming disaster relief operations. Establishing agencies are responsible for their operation.
- **Call Center** – Where the public can call with donation offers. Call center staff can also provide advice on how to assist those affected by disaster in the most effective ways possible. Call takers can gather information about offered goods to pass on

to donation management personnel.

OTHER CONSIDERATIONS

Personnel

Each donation facility will require staff members to operate effectively. The workload and hours of operation will affect the numbers of staff dramatically. Typically, a combination of personnel from local government and voluntary organizations can staff the donations management facilities. Unaffiliated disaster volunteers and support from the local business community may also be available to assist.

Equipment

Pallet jacks, racking, and other equipment needed for donation management may be available for loan from local businesses. They may be donated or rented from equipment rental shops. The American Logistics Aid Network (ALAN), a National VOAD member, or the SEOC may be able to assist.

Transportation

Work with local delivery companies to arrange for donations to flow between collection centers, warehouses and distribution centers. Possible transportation resources include local package delivery services and trucking companies. Don't forget fuel, oil and maintenance costs for vehicles used. Drivers must be properly licensed and insured to operate vehicles.

Record-Keeping

Keeping track of goods being donated by the public is an important function. Donation managers need to know what is being offered, received, stored, and distributed to people affected by disasters. To do this, managers should establish a record-keeping system and keep receipts. This can be done using specialized software, spreadsheets, or manually using paper forms and logs.

Sample forms and logs can be found in [Attachments C1](#) and [C2](#) to this guidebook. Consider contacting Adventist Community Services - Disaster Relief to learn more about managing donated goods during a disaster and perhaps sign a Memorandum of Understanding in advance.

Excess Donated Materials

Redistribution or disposal – Donated goods that remain after initial disaster needs are met can be re-purposed to meet other community needs. Examples include:

- Providing goods to established local Long-Term Recovery Groups to address unmet needs
- Offering food items whose shelf-life has not expired to local food banks/food shelves
- Offering non-food goods to local organizations and programs that assist with non-disaster community needs such as Goodwill, housing assistance, etc.
- More options are included in [Attachment J](#)

CASH DONATIONS

If possible, avoid the temptation to establish a jurisdiction or elected official's fund to collect financial contributions. It is helpful to discourage independent fundraising or crowdfunding efforts since there is no accountability for how the funds raised are used. Advise donors to donate directly to voluntary organizations active in disasters.

Be prepared, however, to deal with cash from well-meaning donors, despite efforts to direct their financial contribution to voluntary organizations. A local foundation, nonprofit or United Way could establish a Disaster Donation Fund to collect monetary donations, thank donors and distribute the funds.

If permitted by local ordinances and other guidance, the best approach to deal with these funds may be to make them available to long-term recovery groups (LTRG) to help cover unmet needs of those affected by disaster. Caseworkers affiliated with voluntary organizations participating in the LTRG will verify the needs to the group distributing the funds.

Have a conversation with the city, county or tribal attorney about the possibility of doing this and about appropriate methods for distributing and accounting for the funds. Avoid the enticement and the pressure to distribute donated funds immediately. Waiting will prevent unnecessary duplication of services provided by insurance settlements, voluntary organization or government disaster assistance programs.

LINKS

[MN Statewide Available Properties \(DEED\)](http://www.mn.gov/deed/business/locating-minnesota/land-bldg/statewide)

www.mn.gov/deed/business/locating-minnesota/land-bldg/statewide

RESOURCES

[Attachment B – Facility Specifications and Staffing Recommendations](#)

[Attachment C1- Donated Goods and Services Intake Form](#)

[Attachment C2 – Unsolicited Donated Goods Inventory Log](#)

[Attachment I – Sample Donated Goods Category Numbering List](#)

[Attachment J - Excess Donated Material Goods Distribution Resources](#)

[Attachment K – Donation Information: Crowdfunding and Software](#)

Lesson Learned:

“Service to others is the rent you pay for your room here on earth.”

Muhammad Ali –
Athlete/Activist

CHECKLIST

Chapter 4 – Donated Goods

- Work with Adventist Community Services Disaster Relief to help plan to manage donated goods. Perhaps sign an MOU in advance of a disaster.*
- Survey facilities to use as collection centers, warehouses and distribution centers.*
- Arrange for supplies and office or material handling equipment and other support for all facilities.*
- Staff each facility established, as appropriate.*
- Arrange for transportation of goods between facilities.*
- Account properly for all donated goods and funds.*
- Consider how to redistribute unused donated goods.*

VOLUNTEER AND DONATION MANAGEMENT GUIDEBOOK

CHAPTER 5 –

UNAFFILIATED VOLUNTEER MANAGEMENT

*Most Important Task: Identify at least two facilities
in the jurisdiction that could serve as
Volunteer Reception Centers.*

Unaffiliated disaster volunteers are the responsibility of local governments, according to Minnesota Statutes, Chapter 12.22a. The statute goes on to say, “Individuals who volunteer to assist a local political subdivision during an emergency or disaster who register with that subdivision and who are under the direction and control of that subdivision are considered an employee of that subdivision for purposes of worker’s compensation and tort claim defense and indemnification.”

This chapter provides guidance on how to manage unaffiliated disaster volunteers and establish a Volunteer Reception Center (VRC). It will also cover the development of partnerships with voluntary organizations to support unaffiliated volunteer management efforts. Refer to Attachments [B](#), [E](#), [H](#), [L](#) and [M](#) for resources.

GENERAL VOLUNTEER MANAGEMENT CONCEPTS

Responsibilities

The Unaffiliated Volunteer Group Supervisor is responsible for coordinating and managing the efforts of **unaffiliated** disaster volunteers. They are considered unpaid employees of the jurisdiction for purposes of liability and Worker’s Compensation and must register before assisting.

The coordination of MNVOAD agencies is the responsibility of the Local VAL, Logistics

Chief or designee. The day-to-day supervision of volunteers who are **affiliated** with a voluntary organization partner are the responsibility of that specific organization. In this case, management and liability issues are between the voluntary organization and the volunteer themselves.

In some cases, local governments may request that voluntary organizations assist them with unaffiliated volunteer work crews. This approach would be acceptable, as long as it is made clear beforehand which organization will be responsible for the volunteers and who will cover liability issues that may arise.

Given the possibility of exposure to liability and Worker’s Compensation issues, make sure to include the jurisdiction’s Risk Manager and an agency representative that provides liability and Worker’s Compensation coverage to the jurisdiction in the volunteer planning process. Refer to the links section in this chapter for information.

Public Messaging

Media coverage of the disaster/emergency may trigger an almost immediate response from the public to volunteer their services. Work with the Public Information Officer (PIO) to distribute appropriate messages.

VOLUNTEER RECEPTION CENTER

The Volunteer Reception Center (VRC) is a place where the general public offer their

services to help people that are affected by disaster to begin their recovery.

This is where unaffiliated volunteers are registered, screened, credentialed, trained and referred to voluntary organizations. They could also be organized into work crews under a supervisor appointed by the local government. The volunteers are then issued necessary equipment and transported to their worksite. When their work is completed, volunteers return to the VRC for out-processing.

It is a good idea to identify more than one possible facility to use as a Volunteer Reception Center. The primary location choice could be affected by the disaster, emergency or may be otherwise unavailable. Also keep in mind what the building is normally used for. Any use of armories must be approved by the Minnesota Department of Military Affairs and be coordinated through the State Duty Officer or SEOC. If a school, faith-based building or courthouse is used, the facility may have to be vacated when school is open or when other events are scheduled.

Volunteer Reception Center – Stations:

- **Station #1 - Registration** – Incoming volunteers are welcomed here. They are provided a volunteer instruction sheet and asked to sign in.
- **Station #2 - Interview** - Volunteers are interviewed and assigned to work in specific areas. They could also be referred to a partner voluntary organization in accordance with their capabilities, limitations and with operational needs. Make sure to provide opportunities for volunteers with all levels of ability.
- **Station #3 – Data and Agency Coordinator** - Volunteers bring their referral forms here. The coordinator

matches the assignment recommendation from the interviewer with a corresponding request for volunteers.

- **Station #4 - Orientation and Safety Briefing** - Information about the operation, the duties the volunteer will be performing and required safety guidance will be provided here.
- **Station #5 – Volunteer Identification** – Volunteer will be provided with appropriate identification wristband or ID badge. They will be advised how to connect with the group they will be assisting and where to find their work crew supervisor.
- **Station #6 - Equipment Issue** – Maps, personal protective equipment (PPE), and tools required by volunteers will be issued at this station.
- **Station #7 – Position Task Training** – Volunteers who require just-in-time training to perform their duties receive instruction at this station. Volunteers who are referred to another agency will generally receive training on how to perform their duties from the agency that requested them.
- **Station #8 - Transportation** – This is typically provided by an arrangement with local public or school bus companies. Charter bus companies or faith-based groups may also be able to assist.

Do not allow unaffiliated volunteers to drive themselves to the work site. Their cars would congest the area around the disaster scene and could possibly be damaged. It would also make it very difficult to have all unaffiliated volunteers check-in and check-out at the end of the work shift. Volunteers that have been referred to another agency may be asked to

travel to their location themselves.

- **Station #9 – Check-Out** - Volunteers who have completed their shift must sign out of the registration tracking log, return equipment, and visit the First Aid station if they are injured. This can also be the station to thank them for volunteering.

Additional VRC Functions to Consider

- **Restroom Facilities and Handwashing Stations**
- **Water and Refreshments** - For incoming volunteers, VRC staff and volunteers
- **Supply Storage** – For tools and PPE
- **Public Information Office and Media Staging area**
- **An Area for Runners and Security Staff**
- **A Patrolled Parking Area for VRC Staff and Volunteers**
- **First Aid Stations** – At the VRC and at the worksite, to care for volunteers and staff that may be injured or suffer a medical emergency while performing duties. These stations may be staffed by local public health, ambulance service or voluntary organization medical personnel.

Other Considerations

- **Staffing** – Strategies for staffing volunteer management and volunteer reception center positions are discussed in chapter 2. Having government employees, voluntary organizations and unaffiliated volunteers working together to staff volunteer management facilities seems to be the most successful approach.
- **Field Support** – Team Leaders will supervise tasks of work crews. They will also arrange for water, food service, and sanitary facilities for volunteers working under harsh conditions in the field. A voluntary organization partner such as the

American Red Cross or Salvation Army may be able to assist with this task.

- **Security** – Those affected by disaster are sometimes targeted by unscrupulous contractors and others with ulterior motives. With these possibilities in mind, establish identification systems for volunteers, and provide protection for volunteer vehicles and property while they are serving on their assignments.
- **Record-Keeping** – The following forms should be completed by potential volunteers and retained by the volunteer reception center for record:
 - Registration – Volunteer registration and volunteer time tracking logs.
 - Training – Records of both orientation and any just-in-time training.
 - Financial Records – Bills, invoices and other financial reports associated with the VRC should be retained and provided to the jurisdiction’s Finance Officer for payment.
 - Injury Reports – First reports of injury and follow-ups should be routed through the Safety Officer to the Volunteer and Donation Coordinator for processing and filing.
 - Facility Records – Facility surveys, use and release agreements, facility rental and utility bills and other documents that reflect charges, payments, etc.
 - Impact of Volunteers – Record how volunteers assisted with the response, beyond just the number of volunteers and the hours that they helped. Ask the PIO to take photos and videos.

LINKS

[MN Statutes 12.22 \(Volunteer Protection\)](#)

<https://www.revisor.mn.gov/statutes/?id=12.22>

RESOURCES

[Attachment B – Facility Specifications and Staffing Recommendations](#)

[Attachments E3- E5 – Unaffiliated Volunteer Group Supervisor Position Checklists](#)

[Attachment H – Sample Volunteer Center Floor Plan](#)

[Attachment L – Volunteer Recruitment Resources](#)

[Attachment M - Volunteer Management and Recognition Resources](#)

Lesson Learned:

“The best way to find yourself is to lose yourself in the service of others.”

Mahatma Gandhi –
Attorney and Activist

CHECKLIST

Chapter 5 – Volunteer Management

- Work with Unaffiliated Volunteer Group Supervisor and PIO to create messages about volunteering.*
- Work with Unaffiliated Volunteer Group Supervisor to establish a plan, and staff Volunteer Reception Center (VRC) and its processing stations.*
- Pre-Identify transportation of volunteers to and from worksites with Unaffiliated Volunteer Group Supervisor and local transportation companies.*
- Create a welcoming and appreciative environment for all volunteers, both affiliated VOAD and unaffiliated volunteers.*
- Contact the HSEM Volunteer Resource Coordinator for additional assistance if needed.*

APPENDIX: GUIDEBOOK ATTACHMENTS

Alter the template attachments to meet the needs of the jurisdiction.

- Attachment A – [Volunteer and Donation Leadership Position Descriptions](#)
- Attachment B – [Facility Specifications and Staffing Recommendations](#)
- Attachment C – [Volunteer and Donation Forms and Logs](#)
- Attachment D – [Public Information Guidance and Sample News Releases](#)
- Attachment E – [Duty Checklists for Major Functions](#)
- Attachment F – [Minnesota United Way “211” Call Centers](#)
- Attachment G – [“10 Point” National Volunteer and Donation Management Strategies \(FEMA\)](#)
- Attachment H – [Sample Volunteer Reception Center Floor Plan](#)
- Attachment I – [Sample Donated Goods Category Numbering List](#)
- Attachment J – [Excess Donated Material Goods Distribution Resources](#)
- Attachment K – [Donation Information: Crowdfunding and Software](#)
- Attachment L – [Volunteer Recruitment Resources](#)
- Attachment M – [Volunteer Management and Recognition Resources](#)
- Attachment N – [Template Plan: Volunteer and Donation Management Plan](#)

Attachment A1 - Position Description

Position: Local Voluntary Agency Liaison (VAL)

Title: Local Voluntary Agency Liaison (VAL)

Reports to: Local City/County/Tribal Director of Emergency Management or Logistics Chief

Position Summary

The Local Voluntary Agency Liaison (VAL) assists the Director of Emergency Management or Logistics Chief. The Local VAL will appoint or serve as the coordinator for the Volunteer and Donation Coordination Team (VDCT) to manage the overall unsolicited donated goods and unaffiliated volunteer management operation. The VAL may function in a multi-city/county/tribal or regional jurisdiction, traveling to the location where most needed.

One volunteer or employee or a small team working together may fill this position. Teams may provide flexibility if several locations are affected or if a team member is not able to respond to a specific disaster. It may be helpful to appoint a Local VAL Team Leader to guide the group.

Basic Functions of the Local Voluntary Agency Liaison

- Managing the handling of unsolicited offers of donated goods, so that needed goods are received and provided to those affected in a timely and efficient manner.
- Managing the services of unaffiliated disaster volunteers, so that volunteer services are provided to those that need them, in a timely and efficient manner.
- Managing the distribution of undesignated donations of funds, so that monetary assistance is provided to people affected by disaster in a fair and equitable manner, distributed according to verified need.
- Collaborating with Minnesota Voluntary Organizations Active in Disaster (MNVOAD) member organizations and local VOAD/COAD groups that provide assistance during disaster.
- Coordinating with the supervisor of Community Emergency Response Team (CERT) or other volunteer groups.
- Coordinating with Local Emergency Operations Center (EOC) officials, government agencies, voluntary organizations and the business community to establish Donated Goods/Funds and Volunteer Service management functions, as appropriate, for disaster/emergency situations.
- Supervising the Volunteer and Donation Coordination Team (VDCT) to identify needs for unsolicited donated goods and unaffiliated volunteer services and to conduct donations intelligence (i.e. gathering information about factors that have a potential impact—negative or positive—on the program) and tracking rumor control.
- Coordinating media releases concerning donated goods, funds and volunteer services with the local Public Information Officer (PIO) to inform the business community and the public about how to donate goods/offer services in the most effective manner possible, to assist those affected by disaster/emergency.
- Working with the VDCT to establish an effective field logistics system for volunteer and donation support operations.
- Serving as a liaison to other components of the disaster response team.
- Coordinating operations with the phone bank supervisor, or with United Way “211” staff (in

communities using 211 services).

- Maintaining a link with other Local/State/Federal donations management efforts.
- Coordinate or assist with the coordination of the local COAD group.

Minimum Requirements/Abilities (or be willing to learn)

Volunteers or staff members appointed to serve as the Local Voluntary Agency Liaison must demonstrate good interpersonal skills when dealing with government agency, EOC management and staff, representatives from voluntary organizations active in disaster (MNVOAD), emergency response personnel, donors, the public, and representatives of the business community participating in disaster/emergency response operations.

Local Voluntary Agency Liaison must be well versed the concepts surrounding the handling of unsolicited donated goods, the management of unaffiliated volunteers and strategies for managing undesignated donated funds.

Local VAL must also possess basic computer skills and familiarity with MS Word (word processing), MS Excel (spreadsheet) and MS Outlook (messaging/calendar software) and software chosen to support donations and volunteer management efforts. Consult with the local Director of Emergency Management if you need to borrow computer or other equipment to fulfill the duties.

A background check may be required, depending upon local policies. A current driver's license and a clean driving record may be necessary, if duties assigned require the use of a vehicle.

Public speaking skills may be required if asked to communicate needs/donation instructions to the public thru media interviews (optional).

Training Requirements

All courses are free and additional training opportunities may be offered by voluntary organizations that are active in disaster or HSEM.

The Local Voluntary Agency Liaison should successfully complete the following FEMA/State level emergency management courses: (within one year of appointment)

- Volunteer and Donation Management Workshop (G-288)
- The Role of Voluntary Agencies in Emergency Management (IS-288)
- Incident Command - Entry/Basic/Intermediate/Advanced Levels (ICS 100, 200, 300, and 400) (FEMA version or MNIMS equivalent)
- National Incident Management System (NIMS) An Introduction (IS-700)
- National Response Plan (NRP) An Introduction (IS-800)

The following courses are recommended for Local Voluntary Agency Liaisons where Community Emergency Response Teams (CERT) have been established or are being considered:

- CERT Program Manager (E-0427)
- CERT Train the Trainer (E-0428)

Local Voluntary Agency Liaisons must also become proficient with EOC management software and with the system established to keep records about donated goods/funds/volunteer service offered.

Time Commitment for the Position

The Local Voluntary Agency Liaison should inform the Director of Emergency Manager of their availability. Lengths of shifts may vary but should not be more than eight hours a day. Twelve hour shifts may be permissible for a short period while additional support is being scheduled.

Length of Appointment

Local Voluntary Agency Liaison (VAL) may serve in the position for as long as they wish, with the approval of the local Director of Emergency Management. It is advisable for the VAL to attend meetings to remain informed during periods of “blue-sky/steady state.” When a disaster occurs, it is expected that the VAL will assist during the duration of the disaster. Aiding the long-term recovery efforts is encouraged.

Supervision and Support

The Local Voluntary Agency Liaison will work in cooperation with and under the direction of the Local Director of Emergency Management. The VAL (or VAL Team Leader) will oversee the activities of Group Supervisors appointed to VDCT positions and work with government staff, voluntary organizations, businesses and community representatives with an interest in managing donated goods, volunteer services or donations of funds to victims of disaster. The Local VAL will also collaborate with other EOC representatives and with the HSEM Volunteer Resource Coordinator and representatives of Minnesota Voluntary Organizations Active in Disaster (MNVOAD) for assistance from organizations outside of the local area.

Disclaimer

The above statements are intended to describe the general nature and level of work being performed by people assigned to this position. They are not to be construed as an exhaustive list of all responsibilities, duties, and skills required of personnel. All personnel may be required to set aside normal responsibilities from time to time, as needed.

Attachment A2 - Position Description
Volunteer and Donation Team Coordinator

Title: Volunteer and Donation Team Coordinator

Reports to: Local Voluntary Agency Liaison (VAL), Logistics Chief or Emergency Manager

Position Summary

The overall mission of the Volunteer and Donation Team Coordinator is to coordinate or manage the handling of unsolicited offers of donated goods, services of unaffiliated disaster volunteers and undesignated donations of funds, so that needed goods and services are received in an effective and timely manner and unneeded goods and services are kept out of the disaster area. The Local VAL may fill this position.

Basic Functions of the Volunteer and Donation Team Coordinator

- Coordinate with EOC officials, government agencies, voluntary organizations and the business community to establish Donated Goods/Funds and Volunteer Service management functions, as appropriate for disaster/emergency situations.
- Work with Donated Goods and Volunteer Service Group Supervisors to identify needs for unsolicited donated goods and unaffiliated volunteer services.
- Coordinate media releases concerning unsolicited goods and services with Public Information Officer.
- Conduct donations intelligence (i.e., particularly gathering information about factors that have a potential impact—negative or positive—on your program) and tracking rumor control.
- Working with Group Supervisors, establish an effective field logistics system for Volunteer and Donation support operations.
- Processing offers of unsolicited goods and services.
- Serving as a liaison to other components of the disaster response team.
- Coordinating operations with the phone bank supervisor.
- Coordinating effective field logistics.
- Coordinating with emerging organizations and spontaneous or unaffiliated volunteers.

The VD Team Coordinator Responsibilities

- Activating the Donations Management plan
- Determining the requirement for and level of support from other agencies and organizations (e.g., other state agencies, voluntary organizations FEMA, business and industry)
- Managing the Volunteer and Donation operations
- Maintaining a link with Local/State/Federal donations management efforts
- Coordinating operations with phone bank supervisors
- Ensuring logistical support to donations management operations
- Deciding when to demobilize the response operation
- Informing the business community and the public about how to donate goods/offer services in

the most effective manner possible to assist those affected by disaster/emergency

- Scaling back and/or closing the donations operations when appropriate
- Scaling down the use of facilities when no longer needed
- Disposing of remaining goods
- Conducting a critique (“hot wash”)
- Completing a comprehensive after-action report
- Delegating responsibilities as necessary

Minimum Requirements/Abilities (or willing to learn)

People appointed to serve as the Volunteer and Donation Team Coordinator must demonstrate good interpersonal skills when dealing with EOC management and staff, representatives from voluntary organizations active in disaster, emergency response personnel, donors, the public, and representatives of the business community participating in disaster/emergency response operations.

Volunteer and Donation Team Coordinator must be well versed in the concepts surrounding the handling of **unsolicited** donated goods, the management of **unaffiliated** volunteers and strategies for managing **undesigned** donated funds. A current driver’s license and a clean driving record are necessary, if duties assigned will require the use of a vehicle.

A background check may be required, depending upon the situation. Staff members selected must possess basic computer skills and familiarity with MS Word (word processing), MS Excel (spreadsheet) and MS Outlook (messaging/calendar software). Public speaking skills may also be required if asked to communicate needs/donation instructions to the public thru media interviews (optional).

Training Requirements

The Volunteer and Donation Team Coordinator should successfully complete the following FEMA/State level emergency management courses: (within one year of appointment)

- Volunteer and Donation Management Workshop (G-288)
- The Role of Voluntary Agencies in Emergency Management (IS-288)
- National Incident Management System (NIMS) An Introduction (IS-700)
- National Response Plan (NRP) An Introduction (IS-800)
- Incident Command (Entry/Basic/Intermediate/Advanced Levels) (ICS 100-400) (FEMA version or NIMS equivalent)

Volunteer and Donation Team Coordinators must also become proficient with EOC management software and with the system established to keep records about donated goods/funds/volunteer service offered.

Additional training opportunities may be offered by voluntary organizations that are active in disaster or HSEM.

Time Commitment for the Position

A Volunteer and Donation Team Coordinator is assigned at all times when the Volunteer and Donation function is operational. When conditions permit, Volunteer and Donation Team Coordinators and their staff will be assigned to shifts of no more than eight hours per day. Twelve hour shifts may be permissible for a short period while additional support is being scheduled.

Length of Appointment

Volunteer and Donation Team Coordinator may serve in the position for as long as they wish, with the approval of county emergency management leadership, Local VAL and the EOC Logistics Chief.

Supervision and Support

Volunteer and Donation Team Coordinator will work in cooperation with and under the direction of the county Emergency Management Director or Local VAL and the EOC Chief of Logistics during times of EOC activation. The Director or Local VAL will oversee the activities of Group Supervisors appointed to Volunteer and Donation Coordination Branch positions. The Volunteer and Donation Team Coordinator will also collaborate with other SEOC representatives and with representatives of Minnesota Voluntary Organizations Active in Disaster (MNVOAD) and businesses with an interest in managing donated goods, volunteer services or donations of funds to victims of disaster.

Disclaimer

The above statements are intended to describe the general nature and level of work being performed by people assigned to this classification. They are not to be construed as an exhaustive list of all responsibilities, duties, and skills required of personnel so classified. All personnel may be required to perform duties outside of their normal responsibilities from time to time, as needed.

Attachment A3 - Position Description

Unsolicited Goods/Undesignated Funds Group Supervisor

Title: Unsolicited Goods/Undesignated Funds Group Supervisor

Reports to: Volunteer and Donation Team Coordinator or Local VAL

Position Summary

The overall mission of the Unsolicited Goods and Undesignated Funds Group Supervisor is to assist local/county donations managers. Coordinate or manage the handling of unsolicited offers of donated goods and undesignated donations of funds. Ensure that the goods and services needed are received in an effective and timely manner and unneeded goods and services are kept out of the disaster area.

Basic Functions of the Unsolicited Goods/Undesignated Funds Group Supervisor

- Coordinate with local and county EOC officials, government agencies, voluntary organizations and the business community to assist them with establishment of Donated Goods and funds management functions, as appropriate for disaster/emergency situations.
- Work with the Volunteer and Donation Team Coordinator and Unaffiliated Volunteer Group Supervisor to identify needs for unsolicited donated goods and management of undesignated donated funds.
- Coordinate state-level media releases concerning unsolicited goods and donated funds with the Volunteer and Donation Coordinator and the Public Information Officer.
- Conduct donations intelligence (i.e., particularly gathering information about factors that have a potential impact—negative or positive—on your program) and tracking rumor control.
- Working with the Volunteer and Donation Team Coordinator and other group supervisors, assist with establishment of an effective field logistics system for donations and fund management operations.
- Work with group staff to process **unsolicited** goods/**undesignated** donated funds. The goal is to process all offers of goods and funds within 72 hours of the time the offer was made.
- Serving as a liaison to other components of the disaster response team.
- Coordinating operations with the phone bank supervisor.
- Make recommendations to “scale down” donated goods facilities as they no longer become necessary.
- Make recommendations for disposing of surplus donated goods.

Minimum Requirements/Abilities (or willing to learn)

Staff members appointed to serve as the Unsolicited Goods/Undesignated Funds Group Supervisor must demonstrate good interpersonal skills when dealing with local volunteer and donations managers, EOC management and staff, representatives from voluntary organizations active in disaster, emergency response personnel, donors, the public, and representatives of the business community participating in disaster/emergency response operations.

Group supervisors must be well versed in the concepts surrounding the handling of **unsolicited** donated goods, the management of **unaffiliated** volunteers and strategies for managing **undesignated** donated funds.

A current driver's license and a clean driving record are necessary, if duties assigned require the use of a vehicle. A background check may be required, depending upon the situation. Staff members selected must possess good basic computer skills and familiarity with MS Word (word processing), MS Excel (spreadsheet) and MS Outlook (messaging/calendar software). Public speaking skills may also be required if asked to communicate needs/donation instructions to the public thru media interviews (optional).

Training Requirements

Unsolicited Goods/Undesignated Funds Group Supervisors should successfully complete the following FEMA/State level emergency management courses: (within one year of appointment)

- Local Volunteer and Donations Management (G-288)
- The Role of Voluntary Agencies in Emergency Management (IS-288)
- National Incident Management System (NIMS) An Introduction (IS-700)
- National Response Plan (NRP) An Introduction (IS-800)
- Incident Command - Entry/Basic/Intermediate/Advanced Levels (ICS 100-400) (FEMA version or MNIMS equivalent)

Group supervisors must also become proficient with EOC management software and with the system established to keep records about donated goods/funds/volunteer service offered.

Additional training opportunities may be offered by voluntary organizations that are active in disaster and HSEM. Unsolicited Goods/Undesignated Funds Group Supervisors may also be required to demonstrate basic level accounting and cash-handling skills when dealing with donated funds.

Time Commitment for the Position

An Unsolicited Goods/Undesignated Funds Group Supervisor is assigned at all times when the donated goods function is operational and goods donations or funds are being received. When conditions permit, group supervisors and their staffs will be assigned to shifts of no more than eight hours per day. Twelve hour shifts are permissible for a short period while additional support is being scheduled.

Length of Appointment

Unsolicited Goods/Undesignated Funds Group Supervisors may serve in the position for as long as they wish, with the approval of the Volunteer and Donation Team Coordinator, emergency management leadership and the EOC Logistics Chief.

Supervision and Support

Unsolicited Goods/Undesignated Funds Group Supervisors work in cooperation with and under the direction of the Volunteer and Donation Team Coordinator and the Local Voluntary Agency Liaison (VAL) during times of EOC activation. Group Supervisors manage staff members appointed to assist with operations of their function. They also collaborate with other SEOC representatives and with representatives of Minnesota Voluntary Organizations Active in Disaster (MNVOAD) and businesses with an interest in managing donated goods, volunteer services or donations of funds to victims of disaster.

Disclaimer

The above statements are intended to describe the general nature and level of work being performed by people assigned to this classification. They are not to be construed as an exhaustive list of all responsibilities, duties, and skills required of personnel so classified. All personnel may be required to perform duties outside of their normal responsibilities from time to time, as needed.

Attachment A4 - Position Description
Unaffiliated Volunteer Group Supervisor

Title: Unaffiliated Volunteer Group Supervisor

Reports to: Volunteer and Donation Team Coordinator

Position Summary

The overall mission of the Unsolicited Goods and Undesignated Funds Group Supervisor is to assist local/county volunteer coordinators to manage the services of unaffiliated volunteers offering to help with relief operations in the wake of a disaster or emergency.

Basic Functions of the Unaffiliated Volunteer Group Supervisor

- Coordinate with local/county volunteer managers, EOC officials, government agencies, voluntary organizations and the business community, assisting with establishment of unaffiliated volunteer management functions, as appropriate for disaster/emergency situations.
- Assign an individual to serve as Unaffiliated Volunteer Group Supervisor and another to serve as a Volunteer Team Coordination Unit Supervisor.
- Work with the Volunteer and Donation Team Coordinator to identify needs for unaffiliated disaster volunteers.
- Coordinate state-level media releases concerning unaffiliated volunteers with the Volunteer and Donation Team Coordinator and the Public Information Officer.
- Conduct volunteer management intelligence (i.e., particularly gathering information about factors that have a potential impact—negative or positive—on your program) and tracking rumor control.
- Working with local volunteer managers, the Volunteer and Donation Team Coordinator and other group supervisors, assist with establishment of an effective field logistics system to support volunteer management operations.
- Work with group staff to process offers of volunteer service from **unaffiliated** volunteers. The goal is to process all offers of volunteer service as soon as possible (but no later than 72 hours) after the offer was made.
- Serving as a liaison to other components of the disaster response team.
- Coordinating operations with the phone bank supervisor.
- Coordinating effective field logistics.
- Make recommendations to “scale down” volunteer operations facilities as they no longer become necessary.
- Maintain volunteer service records.

Minimum Requirements/Abilities (or willing to learn)

Staff members appointed to serve as the Unaffiliated Volunteer Group Supervisor must demonstrate good interpersonal skills when dealing with EOC management and staff, representatives from voluntary organizations active in disaster, emergency response personnel, donors, the public, and representatives of the business community participating in disaster/emergency response operations. Group supervisors must be well versed in the general concepts surrounding the handling of **unsolicited** donated goods, the management of **unaffiliated** volunteers and strategies for managing

undesignated donated funds.

A current driver's license and a clean driving record are necessary, if duties assigned will require the use of a vehicle. A background check may be required, depending upon the situation. Staff members selected must possess good basic computer skills and familiarity with MS Word (word processing), MS Excel (spreadsheet) and MS Outlook (messaging/calendar software). Public speaking skills may also be required if asked to communicate needs/donation instructions to the public thru media interviews (optional).

Training Requirements

Unaffiliated Volunteer Group Supervisors should successfully complete the following FEMA/State level emergency management courses:

- Local Volunteer and Donations Management (G-288)
- The Role of Voluntary Agencies in Emergency Management (IS-288)
- National Incident Management System (NIMS) An Introduction (IS-700)
- National Response Plan (NRP) An Introduction (IS-800)
- Incident Command - Entry/Basic/Intermediate/Advanced Levels (ICS 100-400) (FEMA version or MNIMS equivalent)

Group supervisors must also become proficient with EOC management software and with the system established to keep records about volunteer services offered. Additional training opportunities may be offered by voluntary organizations that are active in disaster.

Time Commitment for the Position

An Unaffiliated Volunteer Group Supervisor is assigned at all times when the Volunteer management functions are operational. When conditions permit, group supervisors and their staffs will be assigned to shifts of no more than eight hours per day. Twelve hour shifts are permissible for a short period while additional support is being scheduled.

Length of Appointment

Unaffiliated Volunteer Group Supervisors may serve in the position for as long as they wish, with the approval of the Volunteer and Donation Team Coordinator, emergency management leadership and the EOC Logistics Chief.

Supervision and Support

Unaffiliated Volunteer Group Supervisors work in cooperation with and under the direction of the Volunteer and Donation Team Coordinator and the EOC Chief of Logistics during times of EOC activation. Group Supervisors manage staff members appointed to assist with operations of their function. They also collaborate with other SEOC representatives and with representatives of Minnesota Voluntary Organizations Active in Disaster (MNVOAD) and businesses with an interest in managing donated goods, volunteer services or donations of funds to victims of disaster.

Disclaimer

The above statements are intended to describe the general nature and level of work being performed by people assigned to this classification. They are not to be construed as an exhaustive list of all responsibilities, duties, and skills required of personnel so classified. All personnel may be required to perform duties outside of their normal responsibilities from time to time, as needed.

Attachment A5 - Position Description

Safety Officer

Title: Safety Officer

Reports to: Volunteer and Donation Team Coordinator, Local VAL, Logistics Chief or
Emergency Manager

Position Summary

The overall mission of the Safety Officer is to ensure that all Volunteer and Donation Coordination Team activities are performed in a safe and efficient manner and that workplace accidents are kept to a minimum. In situations where accidents do occur or safety deficiencies are noted, the Safety Officer will arrange for immediate care for injured personnel, ensure that reports of injury are completed accurately and in a timely manner and that deficiencies which may have contributed to the accident/injury are corrected or mitigated quickly.

Basic Functions of the Safety Officer

- Advise the Volunteer and Donation Team Coordinator and other leadership team members on any safety-related issues that may affect Volunteer and Donation Coordination Team efforts.
- Coordinate with local/county Health and Safety personnel and other team leaders to promote safe working environments at volunteer and donations facilities and worksites.
- Work with the Volunteer and Donation Team Coordinator and EOC Logistics Officer to arrange for first aid kits and other safety equipment to be available at all volunteer and donations management facilities.
- Coordinate with local first responders to develop procedures for summoning emergency personnel to volunteer and donation coordination worksites in the event of serious illness or injury. Ensure that all worksite supervisors have the capability to and knowledge about how to contact first responders in the event of emergency.
- Coordinate with Unaffiliated Volunteer Group Supervisor and Logistics personnel to determine and fill volunteer needs for personal protective equipment (PPE), as appropriate for their duties.
- Make recommendations to “scale down” safety activities as appropriate. Maintain safety records and reports of injury, as appropriate.

Minimum Requirements/Abilities

Staff members appointed to serve as Safety Officers must demonstrate good interpersonal skills when dealing with EOC management and staff, representatives from voluntary organizations active in disaster, emergency response personnel, donors, the public, and representatives of the business community participating in disaster/emergency response operations.

The Safety Officer must be well versed in occupational safety and health issues (Basic Safety Officer Certification as a minimum, advanced certification preferred). A current driver’s license and a clean driving record are necessary, if duties assigned will require the use of a vehicle. A background check may be required, depending upon the situation. Staff members selected must possess good basic computer skills and familiarity with MS Word (word processing), MS Excel (spreadsheet) and MS Outlook (messaging/calendar software).

Training Requirements

Safety Officers should successfully complete the following FEMA/State level emergency management courses: (or within one year of appointment)

- Local Volunteer and Donations Management (G-288)
- The Role of Voluntary Agencies in Emergency Management (IS-288)
- National Incident Management System (NIMS) An Introduction (IS-700)
- National Response Plan (NRP) An Introduction (IS-800)
- Incident Command - Entry/Basic/Intermediate/Advanced Levels (ICS 100-400) (FEMA version or MNIMS equivalent)
- Safety Officers must also become proficient with EOC management software and with the system established to keep records about volunteer services offered.

Time Commitment for the Position

A Safety Officer is assigned at all times when the Volunteer management functions are operational. When conditions permit, Safety Officers will be assigned to shifts of no more than eight hours per day. Twelve hour shifts may be permissible for a short period while additional support is being scheduled.

Length of Appointment

Safety Officers may serve in the position for as long as they wish, with the approval of the Volunteer and Donation Team Coordinator, emergency management leadership and the EOC Logistics Chief.

Supervision and Support

The Safety Officer works in cooperation with and under the direction of the Volunteer and Donation Team Coordinator and the EOC Chief of Logistics during times of EOC activation. They also collaborate with other local emergency responders, EOC representatives and with representatives of Minnesota Voluntary Organizations Active in Disaster (MNVOAD) and businesses with an interest in managing donated goods, volunteer services or donations of funds to victims of disaster.

Disclaimer

The above statements are intended to describe the general nature and level of work being performed by people assigned to this classification. They are not to be construed as an exhaustive list of all responsibilities, duties, and skills required of personnel so classified. All personnel may be required to perform duties outside of their normal responsibilities from time to time, as needed.

Attachment B - Facility Specifications and Staffing Suggestions

FACILITY: Volunteer and Donation Coordination Center and Call Center

A facility where Volunteer and Donation coordination staff match offers of goods and service with needs. It can also serve as the home of the Call Center, if call center duties are not assigned to another agency. Given the mission of the VDCC, it should be located in close proximity to the Emergency Operations Center or be very well connected to it by telephone and computer. *The VDCC is not open to the public.*

The VDCC should be in constant communication with other Volunteer and Donation facilities (collection centers, warehouses, volunteer reception centers, etc).

Facility (for VDCC)

1,000-2,000 square feet of office space (desired)

Staffing Suggestion (per shift)

1 Volunteer and Donation Team Coordinator or Local VAL

1 Unsolicited Goods and Undesignated Funds Group Supervisor

1 Unaffiliated Volunteer Group Supervisor

1 Safety Officer

1 Call Center Supervisor and 15 Call Center Operators (per shift, depending on hours of operation and number of number of operator stations)

Equipment and Supplies

20 phones (5 for VDCC/15 for Call Center)

20 phone lines (5 for VDCC/15 for Call Center) or establish remote phone lines using the Internet (consult with your IT department regarding technology and Wi-Fi requirements)

20 operator headsets (5 for VDCC/15 for Call Center); 25 chairs

10 6-foot folding tables

4 4×8 foot display boards

1 copy machine with paper

1 fax machine with paper and 1 laser printer with paper

6 computer workstations (with Internet and LAN capability) Wi-Fi (if available)

30 State highway system maps

FACILITY: Collection Centers

A facility where donated goods are received, sorted, inventoried and prepared for distribution. Collection Centers should be located outside of a disaster area, near major roads/airports/railheads, if possible. They may be co-located with warehouses for smaller operations. Mobile pop-up Collection Centers may also be an option. Items that are not immediately required are sent to a warehouse for storage until they are needed. *Clients are not served directly at collection centers.*

Size and support suggestions for a collection center: (desired)

Facility (per collection center)

40,000 square feet of covered space (about the size of a typical supermarket) is desired

Minimum of 1 loading dock (2 or more preferred)

Sanitary facilities

Waste disposal, dumpsters, and pickup

Parking or shuttle service

Staging area for trucks

Staffing Suggestion

1 Facility manager

5 Loading dock staff (per shift - 2 with forklift certification if forklifts are available)

10 Sorting area workers (per shift)

Equipment and Supplies

1 Forklift (more for larger operations)

3 Pallet jacks or motorized dollies

Ramps

Packing boxes

Shrink-wrapping equipment

Extra pallets; and Racks for warehousing pallets

Personal Protective Equipment (PPE)

1 First aid kit

Signs and markers

Sorting tables

Fuel and oil for all machinery

Empty trailers

Refrigeration equipment (if cold storage is required)

Conveyors (preferred)

Computers (with Internet access – connected by local area network, if possible);

Printers/Scanners (appropriate for number of computers)

Telephone/radio and Wi-Fi communications (as appropriate and available)

FACILITY: Warehouses

Where goods not immediately needed are stored for later shipment to distribution centers.

Warehouses and Collection Centers may be combined for smaller operations.

Clients are not served at warehouse facilities. Warehouses should be located near major roads, airports and railheads that are *outside of the disaster area*. Warehouses may be co-located with collection centers. Avoid combining warehouse facilities with distribution centers. Size and

support suggestions for warehouses are:

Facility (per warehouse)

Large warehouse: 100,000 – 200,000 sq. ft. (about the size of a large supermarket) is desirable

Small warehouse: 40,000 sq. ft. (about the size of a typical supermarket) may be used for smaller operations

Minimum of 2 loading docks (3 or more preferred)

Sanitary facilities

Waste disposal, dumpsters, and pickup

Parking for staff

Staging area for trucks

Conveyor belts

Staffing Suggestion (per warehouse)

1 Facility manager

5 Loading dock staff per shift (2 with forklift certification if forklifts are available)

10 Warehouse floor workers (per shift)

Equipment and Supplies

2 Forklifts

3 Pallet jacks or motorized dollies

4 Ramps

Packing boxes

Shrink-wrapping equipment

25 Extra pallets/"gaylords" (boxes for loose items), etc.

Racks for warehousing pallets

Personal Protective Equipment (PPE) for workers

1 First aid kit

Signs and markers

Sorting tables

Fuel and oil for all machinery

Empty trailers

Refrigeration equipment (for cold storage, if required)

Computers (connected by WebEOC to the Internet, if possible)

Laser printers (appropriate for number of computers)

Telephones/radio and Wi-Fi equipment for communication, as appropriate

FACILITY: Distribution Centers

Where those affected by disaster come to pick up needed donated items. Distribution Centers should be *located as near to clients as is safely possible* and should not be located in the same facility as collection centers or warehouses. Mobile pop-up Distribution Centers may also be an option. *Distribution Centers are open to clients.*

Size and support suggestions for distribution centers are:

Facility (per distribution center)

Approximately 3,500 square feet of covered floor space (approximately the size of a convenience store) is desired

Minimum of 1 loading dock

Sanitary facilities for workers and clients

Staging area for trucks

Staffing Suggestion (per distribution center)

1 Facility manager

3 Loading dock staff (per shift)

5 Floor workers (per shift)

Equipment and Supplies

Personal Protective Equipment (PPE)

2 Material handling equipment (pallet jacks, etc.)

1 First aid kit

25 pallets/"gaylords" (boxes for loose items), etc.

Computers with Internet access

Material handling logs/forms/software as necessary

Printers

Portable radios

Refrigeration equipment (if cold storage is required)

Telephone service/radio, Wi-Fi and equipment (as necessary)

FACILITY: Volunteer Reception Center (VRC)

A facility where unaffiliated disaster volunteers go to be registered, screened, provided with orientations, training and safety equipment, organized into work parties and dispatched to disaster sites to provide assistance. *Clients are not served at VRC.*

Facility (per VRC)

Approximately 6,000 sq. ft. of space (school gymnasium, civic center, and other public facilities work well as temporary Volunteer Reception Centers) is desirable

Adequate parking for the number of volunteer vehicles expected

Sanitary facilities for staff and volunteers
Staging area for buses/volunteer transportation
Registration area
Registration, liability and other forms, as appropriate
A training/orientation area
An equipment issue area
Personal Protective Equipment (PPE) as appropriate for work parties
Bus drop off/pick up site (arrange for bus transportation to/from disaster worksites)
A media-press area
Space for VRC Manager and staff
2 (or more) First aid kits
 1 at registration center
 1 at each main worksite location

Staffing Suggestion (per shift)

1 Volunteer Reception Center Manager
6 Registrars for Registration and Credentialing station
10 Interviewers for Interview and Assignment station
6 Facilitators for Orientation and Training station
6 Issuers for Safety Equipment/Tool issue station
6 Transportation section staff
Work Party Supervisors – Ideally, 1 supervisor for each 5 volunteers dispatched to honor “span of control” guidance.
5 Facility/Parking area security staff (consider law enforcement reservists), as appropriate
2 First Aid staff (from local public health or from voluntary organizations, as appropriate)

Equipment and Supplies

Computers (connected by LAN and with Internet access if available)
Printers (number based on computers provided)
Portable radio equipment (or Amateur Radio “shadows”) to provide communications between the VRC and work parties in the field, if cellular mobile phone/Wi-Fi towers aren’t working
Personal Protective Equipment (PPE) for volunteers and staff, as appropriate
Tools and other supplies/equipment, as appropriate for deploying volunteers and staff

Additional Support

Transportation – Arrange for transportation to/from worksites for volunteers and staff with busses from local schools, public transportation companies or faith-based groups, etc. All drivers participating must be properly licensed for the equipment being operated.

Attachment C1 - Donated Goods and Services Intake Form

Please print clearly

Call Received by: _____ Date: _____ Time: _____

NOTE: Financial contributions are the best option. Refer all financial contributions to the MNVOAD members (voluntary organization) who are responding to this disaster. Do not solicit donations for any specific organization. If the donor does not wish to contribute to an organization, refer them to _____.

Individual volunteers should register through the Call Center phone line/website.

Donor Name and Information:

First Name: _____ Last Name: _____

Title: _____ Organization/Company: _____

Email: _____

Phone #1: _____ Phone #2: _____

Address: _____

City: _____ State: _____ Zip: _____

County: _____

Donated (free) Goods: _____ or Services: _____

Commercial (vender) Goods: _____ or Services: _____

Type of Resource: (e.g. people, food, clothing, household goods, equipment)

Category: (e.g. group of adult volunteers, water, child items, bedding, tables and chairs)

Sub-Category: (e.g. construction skills, gallon-distilled, socks size 0-3, wool blankets, folding-gently used)

Description Notes:

Total Quantity: _____ Units (#): _____ Measure (e.g. each box): _____

Packaging: _____ Amount (#): _____ Size (e.g. can, dozen, gallon): _____

Palletized: Yes or No Transportation Required: Yes or No (donor is encouraged to provide)

Refrigeration Required: Yes or No Restrictions: Yes or No

Resource Location:

Estimated Value: _____ Available Until: _____

Follow- Up Required: Yes or No

Action Taken: _____ Inventory ID Assigned: _____

NOTE: Offers to provide paid goods or services will be given to Long-Term Recovery Group, if formed

ATTACHMENT C2 - UNSOLICITED DONATED GOODS INVENTORY LOG

Inventory ID	Donor Information	Description	Quantity Offered	Quantity Issued	Quantity Remaining	Notes (Receiving Agencies and Amounts)

Attachment C3 - Volunteer Registration Form

Please Print Clearly

First Name	Last Name		
Address/Apt	City State Zipcode		
Phone (circle): Home Work	Cell Phone		
Your Email Address			
Emergency Contact (EC)	EC Relationship to You		
EC Phone	EC Email		
Your Age: Age 18+ Under age 18 requires a Parental/Guardian Form	Your Gender: Female Male Other		
Are you affiliated with any Disaster Relief Voluntary Organization as a volunteer or paid staff? No Yes If yes, please list organization(s):			
Do you have any Disaster Relief training? If yes, please explain:			
<p>Do you have any of these skills? (check all that apply)</p> <table style="width: 100%; border: none;"> <tr> <td style="width: 50%; vertical-align: top;"> <input type="checkbox"/> Chainsaw Operator <input type="checkbox"/> Chaplain/Spiritual Care <input type="checkbox"/> Childcare (Licensed) <input type="checkbox"/> Commercial Driver's License (CDL) <input type="checkbox"/> Construction/Handyperson <input type="checkbox"/> Custodial <input type="checkbox"/> Data Entry/Clerical <input type="checkbox"/> First Aid Certification (current) <input type="checkbox"/> Food Preparation <input type="checkbox"/> Forklift Operator <input type="checkbox"/> Ham Radio Operator (Licensed) </td> <td style="width: 50%; vertical-align: top;"> <input type="checkbox"/> Heavy-Equipment Operator (backhoe, bobcat) <input type="checkbox"/> Loading/Unloading (30+ lbs) <input type="checkbox"/> Medical Professional (Certified/Licensed) <input type="checkbox"/> Mental Health Professional (Licensed) <input type="checkbox"/> Security <input type="checkbox"/> Shelter/Lodging <input type="checkbox"/> Social Worker (Licensed) <input type="checkbox"/> Sorting (donated items) <input type="checkbox"/> Warehouse Operations (stocking, inventory) <input type="checkbox"/> CERT Team at _____. <input type="checkbox"/> Other: </td> </tr> </table>		<input type="checkbox"/> Chainsaw Operator <input type="checkbox"/> Chaplain/Spiritual Care <input type="checkbox"/> Childcare (Licensed) <input type="checkbox"/> Commercial Driver's License (CDL) <input type="checkbox"/> Construction/Handyperson <input type="checkbox"/> Custodial <input type="checkbox"/> Data Entry/Clerical <input type="checkbox"/> First Aid Certification (current) <input type="checkbox"/> Food Preparation <input type="checkbox"/> Forklift Operator <input type="checkbox"/> Ham Radio Operator (Licensed)	<input type="checkbox"/> Heavy-Equipment Operator (backhoe, bobcat) <input type="checkbox"/> Loading/Unloading (30+ lbs) <input type="checkbox"/> Medical Professional (Certified/Licensed) <input type="checkbox"/> Mental Health Professional (Licensed) <input type="checkbox"/> Security <input type="checkbox"/> Shelter/Lodging <input type="checkbox"/> Social Worker (Licensed) <input type="checkbox"/> Sorting (donated items) <input type="checkbox"/> Warehouse Operations (stocking, inventory) <input type="checkbox"/> CERT Team at _____. <input type="checkbox"/> Other:
<input type="checkbox"/> Chainsaw Operator <input type="checkbox"/> Chaplain/Spiritual Care <input type="checkbox"/> Childcare (Licensed) <input type="checkbox"/> Commercial Driver's License (CDL) <input type="checkbox"/> Construction/Handyperson <input type="checkbox"/> Custodial <input type="checkbox"/> Data Entry/Clerical <input type="checkbox"/> First Aid Certification (current) <input type="checkbox"/> Food Preparation <input type="checkbox"/> Forklift Operator <input type="checkbox"/> Ham Radio Operator (Licensed)	<input type="checkbox"/> Heavy-Equipment Operator (backhoe, bobcat) <input type="checkbox"/> Loading/Unloading (30+ lbs) <input type="checkbox"/> Medical Professional (Certified/Licensed) <input type="checkbox"/> Mental Health Professional (Licensed) <input type="checkbox"/> Security <input type="checkbox"/> Shelter/Lodging <input type="checkbox"/> Social Worker (Licensed) <input type="checkbox"/> Sorting (donated items) <input type="checkbox"/> Warehouse Operations (stocking, inventory) <input type="checkbox"/> CERT Team at _____. <input type="checkbox"/> Other:		
<p>Equipment you have with you and available to use: (with safety equipment)</p> <table style="width: 100%; border: none;"> <tr> <td style="width: 50%; vertical-align: top;"> <input type="checkbox"/> Backhoe <input type="checkbox"/> Bobcat <input type="checkbox"/> Chainsaw <input type="checkbox"/> Forklift <input type="checkbox"/> Passenger Van <input type="checkbox"/> Rakes </td> <td style="width: 50%; vertical-align: top;"> <input type="checkbox"/> Shovels <input type="checkbox"/> Trailer – Covered <input type="checkbox"/> Trailer – Flatbed <input type="checkbox"/> Truck – Dump <input type="checkbox"/> Truck – Pickup <input type="checkbox"/> Other: </td> </tr> </table>		<input type="checkbox"/> Backhoe <input type="checkbox"/> Bobcat <input type="checkbox"/> Chainsaw <input type="checkbox"/> Forklift <input type="checkbox"/> Passenger Van <input type="checkbox"/> Rakes	<input type="checkbox"/> Shovels <input type="checkbox"/> Trailer – Covered <input type="checkbox"/> Trailer – Flatbed <input type="checkbox"/> Truck – Dump <input type="checkbox"/> Truck – Pickup <input type="checkbox"/> Other:
<input type="checkbox"/> Backhoe <input type="checkbox"/> Bobcat <input type="checkbox"/> Chainsaw <input type="checkbox"/> Forklift <input type="checkbox"/> Passenger Van <input type="checkbox"/> Rakes	<input type="checkbox"/> Shovels <input type="checkbox"/> Trailer – Covered <input type="checkbox"/> Trailer – Flatbed <input type="checkbox"/> Truck – Dump <input type="checkbox"/> Truck – Pickup <input type="checkbox"/> Other:		
Other Skills/Equipment:			
<p>Are willing to help in the Volunteer Reception Center? No Yes If yes, please indicate below:</p> <table style="width: 100%; border: none;"> <tr> <td style="width: 50%; vertical-align: top;"> <input type="checkbox"/> Registration/Welcome <input type="checkbox"/> Escort </td> <td style="width: 50%; vertical-align: top;"> <input type="checkbox"/> Equipment (hand out rakes, etc.) <input type="checkbox"/> Language Translation </td> </tr> </table>		<input type="checkbox"/> Registration/Welcome <input type="checkbox"/> Escort	<input type="checkbox"/> Equipment (hand out rakes, etc.) <input type="checkbox"/> Language Translation
<input type="checkbox"/> Registration/Welcome <input type="checkbox"/> Escort	<input type="checkbox"/> Equipment (hand out rakes, etc.) <input type="checkbox"/> Language Translation		
Language Skills: (please list)	Sign Language Skills: No Yes		
Signature	Today's Date		

Attachment C4 - Emergency Management Volunteer Tracking Log

DATE:

TIME:

VOLUNTEER RECEPTION CENTER LOCATION:

REGISTRAR:

Please Print Clearly

NAME (Last, First)	CONTACT NUMBER	TIME IN	TIME OUT	NOTES AND EMAIL
1.	-	-	-	-
2.	-	-	-	-
3.	-	-	-	-
4.	-	-	-	-
5.	-	-	-	-
6.	-	-	-	-
7.	-	-	-	-
8.	-	-	-	-
9.	-	-	-	-
10.	-	-	-	-
11.	-	-	-	-
12.	-	-	-	-
13.	-	-	-	-
14.	-	-	-	-
15.	-	-	-	-
16.	-	-	-	-
17.	-	-	-	-
18.	-	-	-	-
19.	-	-	-	-
20.	-	-	-	-

Attachment D1 - General Sample Messages Regarding Donations

Review this list of guidelines for donating cash and goods after a disaster. Following these guidelines will help you—and help the disaster survivors.

Remember, cash contributions are the best donation

Cash contributions allow professional nonprofit relief organizations to purchase what disaster survivors most urgently need, and to pay for the transportation necessary to distribute those supplies. Financial contributions have no transportation or storage cost. In addition, monetary donations given to recognized organizations active in disaster are often tax deductible. In addition, donation of money allows relief supplies to be purchased at locations as near to the disaster site as possible. Supplies and food, when purchased locally have the advantage of stimulating local economies and ensuring the supplies will arrive as quickly as possible. Visit www.mnvoad.org to learn more.

Don't just bring stuff (even if you think that it is needed)

Confirm that there is a need for goods or materials before you donate. Exactly what is needed can be confirmed by checking with a nonprofit relief organization that has personnel working onsite at the disaster or by calling the phone number set up specifically for a given emergency. Different disasters create different needs. Local climate and culture of the affected area must be considered.

Donate through an organization

Before starting a collection of goods to send to a disaster site, it is essential to locate a reliable relief organization willing to receive the shipment of donated goods. When unsolicited truckloads of items arrive at a disaster site, there is often no place to unload the goods. Too often, items are left in an empty lot to be plundered or rained on and eventually become part of the garbage that must be removed during the cleanup phase of the disaster response.

Plan transportation in advance

Never assume that unsolicited relief supplies will be transported at no charge. Local trucking firms may be willing to help in times of disaster if funds are available to cover part of the expense. Some volunteer agencies may have trucks going to the disaster site that can take donations, or they may be able to identify another group in the area. Prepare to pay for your own shipping costs.

Be sure to have the following list of information when arranging transportation:

- Talk with someone who is coordinating the donations, first. They will serve as the POC (Point of Contact) and know what is needed and where to deliver the items.
- Verification of storage facilities, including special storage needs such as refrigeration, and personnel for offloading at the disaster location. (Boxes should be strong and sized for a single person to carry. If goods are on pallets, make sure that the receiving warehouse has unloading equipment.)
- Inventory of goods to be transported. Approximate value of goods to be transported.
- Approximate weight of total load to be transported.

- Ensure that donated items are packed well and clearly labeled.
- It is more efficient when items sent are already sorted, labeled, and ready for distribution. Specific content lists should be taped to the side of each box sent. This allows officials to determine quickly what the box contains without opening it. Food is generally distributed in packs containing one or two meals per bag. To save relief workers' time, non-perishable food donations in smaller packages (single serving) are preferred over bulk packaging, unless donating to a voluntary organization involved with mass feeding.
- Clothing should be packed in separate boxes according to gender, size, and season.

Please do not send small items, unsorted clothing, or shoes

Miscellaneous, unrequested items and unsorted bags of clothing or shoes may not reach a disaster area because of handling difficulties. This type of donation may be more appropriately given to a local charity, homeless shelter, or food bank. Call 211 for a list of local charities.

Donate to the local Long-Term Recovery Group

Cash donations may be sent to the local Long Term Recovery Group fund. These funds will be directed to people affected by the disaster who encounter extra needs not covered by insurance and other challenges. The jurisdiction may have a Disaster Relief Fund established to collect these financial donations which will then be distributed by the local Long-Term Recovery Group.

Thank you!

Attachment D2 - General Sample Messages for Volunteer Service

Review this list of guidelines for volunteer service before volunteering after a disaster. Following these guidelines will help you—and help the disaster survivors.

Don't "Just Go"

Though your intentions are good, never self-deploy or show up at a disaster site. It may be dangerous for you and interfere with the response of trained professionals. Please wait until the local authorities ask for helpers.

Prepare for self-sufficiency

Register at the Volunteer Reception Center when you arrive. The local authorities must prepare facilities for feeding, personal hygiene, and health/medical needs for unaffiliated volunteers. Therefore, it is best to work with a recognized voluntary organization as the first step in involvement.

Be patient and flexible

Volunteers should be prepared to step into any of a variety of entry-level roles, depending on current or suddenly discovered needs. Every role is important, may that be picking up debris or filling a sandbag. Sometimes a volunteer's unique talents are not immediately needed. You may be able to help with the long-term recovery efforts after the initial response has finished.

Know the liability situation

A volunteer must register at the Volunteer Reception Center to be covered with liability insurance from the government or voluntary organization with whom the volunteer is assigned. If you don't register at the Volunteer Reception Center, you assume all liability for yourself. Your safety is entirely your own responsibility if you don't register.

Remember that the use of volunteers is a coordinated process

The use of volunteers is an organized process by which people with abilities, skills, and/or training are assigned to special tasks. Volunteers are most useful when they are able to do the right thing at the right time. Volunteers may also be needed for the Long Term Recovery Groups.

Be committed to the response effort

Response and recovery work usually dirty, monotonous, mundane, and not glamorous. Volunteers should be committed to work under such conditions and fit within plans that are coordinated by the local authorities and volunteer agencies. Wear appropriate clothing. Your efforts will be appreciated though you may not be individually recognized due to the hectic nature of disaster response.

Affiliate for the next disaster

Be prepared for the next disaster by joining a recognized voluntary organization. Most are organized under the Minnesota Voluntary Organizations Active in Disaster (MNVOAD) and offer training for their affiliated volunteers. Once you join their organization, you may be able to quickly respond to future disasters.

Thank you!

Attachment D3 – TEMPLATE Public Information Messages – Donations

Sample County
Division of Homeland Security and Emergency Management
555 North Street
Anytown, MN 55720

FOR USE UNTIL April 30, 2022

FINANCIAL DONATIONS

30 SECONDS

Due to the recent flood, Sample County officials encourage people to send cash donations to an organized voluntary organization of your choice that provides assistance during disasters.

At this time, no volunteers, goods or services are needed.

For more information about donations, call the Sample County emergency information line at 1-800-555-1212 for outside calls and (320) 555- 3131 locally.

-End of Message-

Sample County
Division of Homeland Security and Emergency Management
555 North Street
Anytown, MN 56479

FOR USE UNTIL DECEMBER 30, 2022

DONATIONS

15 SECONDS

Due to the recent snow emergency, Sample County Emergency Management is seeking individuals with four-wheel-drive vehicles to transport essential personnel to and from work. If you have a four-wheel-drive vehicle and are interested in helping, please call (218) 555-3854 for more information.

The Sample County is helping to coordinate the donation of money, goods, and services with voluntary organizations that are able to receive, store, and distribute donated items. Please view our website for more information at www.samplecountyec.555 -End of Message-

Attachment D4 – TEMPLATE Public Information Message – Volunteer Help

Sample County

Division of Homeland Security and Emergency Management

555 North Street

Anytown, MN 56258

FOR USE UNTIL JULY 30, 2022

VOLUNTEER HELP

60 SECONDS

Sample County has been receiving numerous offers from well-meaning people who want to assist those affected by yesterday's tornado and severe thunderstorm event.

Local officials thank those who wish to help, but request that all volunteers wait until the area is secured and made safe before coming to assist.

A community clean-up day is scheduled for Saturday, July 30, 2022. Volunteers who wish to help should report to the Sample County Courthouse at 8:00 AM on Saturday to be registered, organized into work crews and transported to work sites. The courthouse address is 1234 5th Street, in Anytown, MN.

Please wear sturdy clothing appropriate to the season. Long pants, long sleeved shirt, sunglasses, and hats are encouraged. Sturdy boots or shoes and gloves are strongly recommended. Please provide your own drinking water, snacks, bug spray, sunscreen and hat. All volunteers must be age 18 and over.

Volunteers who drive directly to the disaster site will not be permitted to enter or assist.

For more information on how you can help, call the Sample County emergency information line at 1-800-555-1212, or (507) 555-3131 locally.

-End of Message-

Attachment E1 –

Volunteer and Donation Team Coordinator

Duty Checklist - Position Description Summary

Reports to: Logistics Chief (EOC), Local VAL or Emergency Manager

Position Function:

Collaborate with government agencies, voluntary organizations, the business community and the public to manage and coordinate unsolicited offers of donated goods, the services of unaffiliated volunteers and undesignated offers of funds that are received to assist those affected by disaster in the most effective, efficient and timely manner possible. Specifically;

Responsibilities:

- Based upon the situation and on information received, determine the scope and size of the donated goods and volunteer coordination effort required.
- Activate the Volunteer and Donation Plan to meet anticipated donated goods and volunteer coordination needs.
- Arrange for staff and facilities to accomplish necessary volunteer and donations management functions. In some cases, voluntary organization personnel may be able to perform staff and management functions.
- Work with staff to support and maintain volunteer and volunteer management operations as long as they continue to be necessary.
- Develop a plan for consolidation and eventual demobilization of volunteer and donation management functions when they are no longer necessary.

Goal:

That unsolicited donated goods, unaffiliated volunteer services and undesignated funds offered in response to disaster are utilized in the most effective manner and that their use (or their management) does not hinder other response and recovery activities.

Volunteer and Donation Team Coordinator - Checklist

COMPLETED	TASK
-	<ul style="list-style-type: none"> • Work with the Logistics Chief to determine which volunteer and donations management functions should be activated, according to verified or projected volunteer or donated goods needs.
-	<ul style="list-style-type: none"> • Set the Volunteer and Donation Branch (VDB) hours of operation. Establish a schedule for Volunteer and Donation Branch meetings.
-	<ul style="list-style-type: none"> • Arrange for a facility to serve as the Volunteer and Donation Coordination Center (VDCC).
-	<ul style="list-style-type: none"> • Establish a log system to track Volunteer and Donation management activities (Work with Donated Goods and Volunteer Group Managers.)
-	<ul style="list-style-type: none"> • Establish a method to keep track of expenses, receipts, contracts, etc.
-	<ul style="list-style-type: none"> • Establish/Maintain contact with voluntary organizations participating in donated goods or unaffiliated volunteer management.
-	<ul style="list-style-type: none"> • Coordinate with Public Information Officer (PIO) about how best to communicate with the public about Volunteer and Donation management issues.
-	<ul style="list-style-type: none"> • Work with Logistics Chief and other local EOC staff to request assistance from HSEM, if it appears that local volunteer and donation management capabilities will be overwhelmed.
-	<ul style="list-style-type: none"> • Contact the leadership of the local “United Way 211” organization to have their operators serve as a “call center” for donated goods, funds/volunteer service offers. If “211” is not available, establish a telephone “hotline.” Establish guidance (“scripts”) or resource guides for 211 operators/call-takers. Update as necessary to reflect current information.
-	<ul style="list-style-type: none"> • Attend emergency operations center (EOC) meetings and briefings, as appropriate. Be prepared to report on status of Volunteer and Donation management functions.
-	<ul style="list-style-type: none"> • Provide support, as required, for donated goods and volunteer management facilities that are established.
-	<ul style="list-style-type: none"> • Establish and maintain contact with Long-Term Recovery groups (LTRG) that form as the disaster phase shifts from response to recovery. Local/Regional COAD, too.
-	<ul style="list-style-type: none"> • Monitor status of group supervisors and other assigned personnel. Ensure that supervisors and staff are given appropriate time off and are replaced or relieved from their assignments when appropriate to avoid “burnout.”
-	<ul style="list-style-type: none"> • Task group supervisors to begin development of plans for demobilization of their functions and facilities.
-	<ul style="list-style-type: none"> • Return facilities and equipment no longer needed/used to owners in a pre-event condition.
-	<ul style="list-style-type: none"> • Distribute donated goods not needed for disaster operations: • Offer surplus goods to participating voluntary organizations, long-term recovery group participants, then to other community service organizations that may benefit from them. • Recycle, compost or dispose of goods/supplies which are unusable.
-	<ul style="list-style-type: none"> • Prepare final reports about the volunteer and donated goods/funds effort for Logistics Officer and other EOC leadership.
-	<ul style="list-style-type: none"> • Participate in After-Action Reports (AARs) that include the volunteer and donated goods management effort.

Attachment E2 –

Unsolicited Donated Goods Funds Group Supervisor

Duty Checklist - Position Description Summary

Reports to: Volunteer and Donation Team Coordinator

Position Function:

Collaborate with Volunteer and Donation Team Coordinator, government agencies, voluntary organizations, the business community and the public. Manage, coordinate and disseminate *unsolicited* donated goods and *undesignated* donations of funds that are offered by the public in the wake of disasters, so that they are provided to assist those affected by disaster in the most effective, efficient and timely manner possible.

Responsibilities:

- Determine the scope and size of the unsolicited donated goods and undesignated funds coordination effort required, based upon the situation and on information received.
- Activate the Volunteer and Donation Plan (if already established) to meet anticipated donated goods and funds coordination needs.
- Arrange for staff and facilities to accomplish necessary donated goods and funds management functions.
- Work with staff to support and maintain donated goods and funds management operations.
- Develop a plan for consolidation and eventual demobilization of donated goods/funds management functions when no longer necessary.

Goal:

Unsolicited donated goods and undesignated donations of funds offered in response to disaster are utilized in the most effective manner and that their management (or use) does not hinder other response and recovery activities.

Unsolicited Donated Goods/Undesignated Donated Funds Group Supervisor - Checklist

COMPLETED	TASK
-	<ul style="list-style-type: none"> • Coordinate with Volunteer and Donation Team Coordinator to determine the scope of unsolicited donated goods and undesignated donations of funds management effort required. • Emphasize that goods/funds received are to be provided to non-profit organizations or long-term recovery groups that are assisting those affected by disaster, but not to contractors or others who are profiting from providing disaster assistance.
-	<ul style="list-style-type: none"> • Activate personnel assigned to perform Unsolicited Donated Goods and Undesignated Funds Unit Leader duties. If multiple shifts or extended donations/fund management operations are required, recruit additional supervisory personnel to serve as unit leaders. • Work with the Volunteer and Donation Team Coordinator and other officials to request additional assistance for donated goods management functions if it appears that local capabilities will be overwhelmed.
-	<ul style="list-style-type: none"> • Establish and maintain contact with voluntary organizations that assist with Unsolicited Donated Goods management. Remember that agencies that solicit (ask for) donated goods are responsible for managing them.
-	<ul style="list-style-type: none"> • Establish a schedule for Unsolicited Donated Goods/Undesignated Funds Group Meetings. Attend branch meetings and briefings. Provide information about donated goods, funds management, address support requirements, and special situations that may arise.
-	<ul style="list-style-type: none"> • Establish Collection Centers, Warehouses and Distribution Center facilities as required to meet donated goods management needs. Base hours of hours of donated goods/funds facilities on needs, keeping safety issues and the news cycle in mind. • Consolidate or curtail use of facilities in a gradual manner when no longer needed. Announce changes well in advance of closures. Return facilities and equipment used to a pre-event condition.
-	<ul style="list-style-type: none"> • Establish log systems to register and track the hours of volunteers assigned to donations management facilities and the receipt and distribution of unsolicited donated goods offered.
-	<ul style="list-style-type: none"> • Ensure that all volunteers and staff perform duties in a safe and responsible manner. Work with team leaders and other personnel to correct safety deficiencies promptly and completely. Forward all reports of injuries promptly to the Volunteer and Donation Team Coordinator for processing.
-	<ul style="list-style-type: none"> • Gather all completed contracts, agreements, invoices, logs, forms and other donations management records. Prepare reports about unsolicited donated goods and undesignated cash management efforts for the Volunteer and Donation Team Coordinator and EOC leadership. • Provide financial records to the Volunteer and Donation Branch Director for forwarding to EOC Administration and Finance for processing.
-	<ul style="list-style-type: none"> • Participate in After-Action Reviews (AARs) which include the unaffiliated volunteer coordination effort.

Attachment E3 –

Unaffiliated Volunteer Group Supervisor

Duty Checklist - Position Description Summary

Reports to: Volunteer and Donation Team Coordinator

Position Function:

Collaborate with government agencies, voluntary organizations, the business community and the public to manage and coordinate the services of unaffiliated volunteers to ensure that services are provided in the most effective, efficient and timely manner possible.

Responsibilities:

- Determine the scope and size of the volunteer coordination effort required
- Activate the Volunteer and Donation Plan to meet anticipated volunteer coordination needs.
- Arrange for staff and facilities to accomplish necessary volunteer management functions.
- Support staff to maintain volunteer management operations.
- Plan for consolidation, demobilization, and transition of volunteer management functions.

Goal:

Unaffiliated disaster volunteers are utilized in the most effective manner possible and that their management (or use) complements recovery activities. Unaffiliated disaster volunteers will be registered, screened, trained, assigned and supervised according to statutes and guidance.

Unaffiliated Volunteer Group Supervisor - Checklist

COMPLETED	TASK
-	<ul style="list-style-type: none"> ● Establish contacts with the local Volunteer Center (if available) and local voluntary organizations that assist with coordination of unaffiliated volunteers <ul style="list-style-type: none"> ○ _____(Local Volunteer Center Contact, if available) ○ _____(Local Contact) ○ _____(Local Contact)
-	<ul style="list-style-type: none"> ● Distribute a press release (in collaboration with PIO), describing how the public can volunteer to assist those affected by disasters. Include the dates, times and locations of Volunteer Reception Center(s), the types of work to be performed and how/ where to report for assignment.
-	<ul style="list-style-type: none"> ● Establish two-way communication between leadership and staff. Attend scheduled Volunteer and Donations Branch meetings and briefings. Convene Unaffiliated Volunteer Group meetings.
-	<ul style="list-style-type: none"> ● Select a site for the Volunteer Reception Center (VRC) and prepare it for operation. ● Perform facility and safety surveys. ● Consolidate volunteer management facilities as needs lessen. ● Return facilities and equipment used to a pre-event condition. ● Gather all completed contracts, agreements, invoices, logs, forms and other volunteer management records. Provide records to the Volunteer and Donation Branch Manager.
-	<ul style="list-style-type: none"> ● Work with Volunteer Reception Center Manager to incorporate safety messages into volunteer training and to issue personal protective equipment (PPE) to volunteers, as appropriate. ● Follow up promptly on any safety issues identified (especially on any reports of injuries of volunteers on assignment).
-	<ul style="list-style-type: none"> ● Request additional assistance for volunteer management functions through Volunteer and Donation Team Coordinator if overwhelmed.
-	<ul style="list-style-type: none"> ● Arrange for transportation of volunteers to and from the VRC and the work area. Possible resources include: ● Discourage volunteers from driving themselves to the impacted area.
-	<ul style="list-style-type: none"> ● Ensure that leaders and staff are given adequate time off and are relieved from their assignments when appropriate to avoid burnout.
-	<ul style="list-style-type: none"> ● Begin development of a plan for consolidation and demobilization of the volunteer coordination function when it is no longer required.

Attachment E4 –

Volunteer Reception Center (VRC) Manager

Duty Checklist - Position Description Summary

Reports to: Unaffiliated Volunteer Group Supervisor

Position Functions:

The Volunteer Reception Center Manager and staff collaborate with Unaffiliated Volunteer Group Supervisor to establish a Volunteer Reception Center (VRC) to manage and coordinate the services of unaffiliated volunteers.

Responsibilities:

- Secure and open the facility to be used as a Volunteer Reception Center (VRC)
- Manage volunteer center set-up, operations and demobilization
- Request staffing and other resources for VRC operations
- Assign and supervise VRC staff
- Coordinate press inquiries regarding unaffiliated volunteers with jurisdiction's PIO
- Maintain close communications with the Unaffiliated Volunteer Group Supervisor

Goal:

Assure that unaffiliated disaster volunteers are properly registered, screened, assigned, trained, managed, equipped and transported to work assignments, so that they can assist those affected by disaster in an effective and safe manner.

Volunteer Reception Center (VRC) Manager - Checklist

COMPLETED	TASK
-	<p>Establish contacts with the local Volunteer Center (as available) and with voluntary organizations that assist with coordination of unaffiliated volunteers.</p> <p style="padding-left: 40px;">_____ (Local Volunteer Center Contact)</p> <p style="padding-left: 40px;">_____ (Local Contact)</p> <p style="padding-left: 40px;">_____ (Local Contact)</p>
-	<ul style="list-style-type: none"> • Choose a site for the volunteer center. Perform facility safety survey. • Arrange for power, water, sanitary, telephone and other utility services. • Post volunteer center identification signs in visible locations on the outside of the building. • Establish operating hours for the VRC Facility. Keep the news cycle in mind. • Facilities and equipment used should be returned in at least the same condition they were in when offered for use.
-	<ul style="list-style-type: none"> • Designate VRC processing stations. Mark each station clearly. Functions to be addressed include: <ul style="list-style-type: none"> ○ Registration & Credentialing (establish a waiting area nearby) ○ Interview & Assignment ○ Orientation & Training ○ Issue Safety Equipment ○ Transportation • Additional areas to consider: <ul style="list-style-type: none"> ○ Supply storage ○ A Public Affairs/Media area ○ A break area for staff ○ An area for “runners” and security personnel ○ A parking area for volunteer vehicles (patrolled by security) ○ First Aid station ○ Feeding area (arrange for feeding with voluntary/community agencies)
-	<ul style="list-style-type: none"> • Establish a system to maintain all required records and documentation related to the VRC. • Work with Finance/Administration to make sure VRC staffing and operations cost tracking follows local, state and FEMA guidelines (as appropriate).
-	<ul style="list-style-type: none"> • Assign personnel to each function according to anticipated needs. • More than one shift may be necessary if the VRC is open for extended hours. Keep “span of control” in mind when making assignments. • Arrange for meals, breaks and refreshments for volunteers and staff • Establish and maintain communications with Unaffiliated Volunteer Coordinator and with VRC staff.
-	<ul style="list-style-type: none"> • Update information about potential work assignments, volunteer guidance and safety information as situations and needs change.

COMPLETED	TASK – <i>VRC continued</i>
-	<ul style="list-style-type: none"> • Plan for demobilization/transition of the VRC. • Determine where to transition remaining volunteer activities within the jurisdiction (e.g., Volunteer Services, Human Resources, Local Volunteer Center).
-	<ul style="list-style-type: none"> • Update information about volunteer opportunities, processing procedures, policies, and safety guidance that changes during VRC operations. • Working with the PIO, publicize information about demobilization or transition of the VRC. • Thanking the volunteers

Attachment E5 –

Volunteer Reception Center (VRC) Staff

Duty Checklist - Position Description Summary

Reports to: Volunteer Reception Center Manager

Position Functions:

Volunteer reception center staff works with the Volunteer Reception Center Manager to establish and operate a Volunteer Reception Center (VRC) to manage and coordinate the services of unaffiliated volunteers.

Responsibilities:

- Help the VRC Manager to open the facility to be used as a Volunteer Reception Center (VRC)
- Assist the VRC Manager with center set-up, operations of the VRC

Staff all of the following positions:

- Registration and Credentialing Interview and Assignment Orientation and Training Safety Equipment Issue Transportation
- Assist the VRC Manager with closing of the facility when it is no longer needed. Consolidate all functional area records and provide to the VRC Manager

Goal:

Unaffiliated disaster volunteers are properly registered, screened, assigned, trained, managed, equipped and transported to work assignments, so that they can assist those affected by disaster in an effective and safe manner.

Volunteer Reception Center (VRC) Staff Function – Specific Guidance Checklists

COMPLETED	TASK
	<p>REGISTRATION & CREDENTIALING FUNCTION</p> <ul style="list-style-type: none"> • Greet all volunteers as they enter the facility. • Refer volunteers who are affiliated with (work for) a voluntary organization (Red Cross, Salvation Army, etc.) directly to their own leadership for registration and supervision. • Refer visitors with non-volunteer related inquiries to the appropriate agency or organization. • Refer media inquiries to the Public Information Officer (PIO). • Handle inquiries from potential volunteers. <p>Create a community resources and referral list for directing other non-volunteer related inquiries (where to donate goods, how to make cash donations, where to get additional help, etc.). Update the information daily, or as new information becomes available.</p> <ul style="list-style-type: none"> • Give all potential unaffiliated volunteers a brief explanation of how the Volunteer Reception Center works. • Have all unaffiliated volunteers register to assist by signing in on a Volunteer Tracking Log. All unaffiliated volunteers must sign in to receive credentials to assist. • Send registered volunteers to the Interview and Assignment function. • Issue identification credentials only to properly registered volunteers. • Credentials should be dated to expire on completion of volunteer duties. • Have all returning volunteers sign out on the tracking log before they leave. Volunteers that serve on multiple days should re-register each day. (see Check-out at the end of this sheet)
	<p>INTERVIEW & ASSIGNMENT FUNCTION</p> <ul style="list-style-type: none"> • Establish and manage the Interview & Assignment function. • Conduct brief interview with each prospective volunteer. • Match volunteer with an appropriate opportunity. • Post urgent needs to recruit volunteers. • Confirm that all volunteers have completed the required paperwork. • Send volunteer to Orientation & Training for further processing. • Conduct a brief interview using the <i>Volunteer Interview Form</i>. Review with volunteer: <ul style="list-style-type: none"> ○ priority skills and abilities ○ whether the volunteer can perform prospective duties ○ physical limitations ○ language skills ○ availability • Review options and match volunteer with most appropriate opportunity. • Briefly explain assignment to volunteer. • Make referrals to other agencies as appropriate. If concerns arise during the interview, DO NOT place the volunteer (ask them to wait) and consult with the Volunteer Registration Center Manager

COMPLETED	TASK – <i>VRC Staff Functions continued</i>
	<p>(Interview & Assignment Function continued)</p> <ul style="list-style-type: none"> ● Issue volunteer ID/credentials ● Instruct volunteer on next steps: <ul style="list-style-type: none"> ○ Where and when to report for orientation and/or training ○ Who will be their supervisor
	<p>ORIENTATION & TRAINING FUNCTION</p> <ul style="list-style-type: none"> ● Plan and provide for orientations and “just in time” Position training for new volunteers/staff. ● Provide general safety training for all volunteers. ● Update orientation and training curriculum as needs, policies or procedures change. ● Address re-training as needed.
	<p>EQUIPMENT ISSUE FUNCTION</p> <ul style="list-style-type: none"> ● Provide necessary equipment for responding volunteers ● Personal Protective Equipment (PPE – Eye and ear protection, N-95 respirators, etc.) ● Tools (rakes, shovels, cell phones/radios) ● Volunteer support items (bottled water, etc.) ● Collect equipment from returning volunteers who have completed their assignments.
	<p>TRANSPORTATION FUNCTION</p> <ul style="list-style-type: none"> ● Discourage volunteers from attempting to drive themselves to their assignments. Parking will be extremely limited and debris could damage volunteer vehicles and cause traffic tie-ups. ● Arrange for volunteer transportation to/from worksites with local city bus, school bus or other transportation companies. ● Coordinate with transportation provider(s) to schedule trips to/from volunteer assignments.
	<p>VOLUNTEER CHECK-OUT (coordinated by the Registration Function)</p> <p>Make certain that all volunteers “check-out” of the VRC before they depart for the day. This will ensure that all volunteers are accounted for and that their time is noted.</p> <ul style="list-style-type: none"> ● Check off their name on the registration tracking log ● Note the time of end of their shift ● Collect any equipment that they may have been given for the assignment ● Refer to First Aid if the volunteer reports any injuries ● Thank the volunteer for assisting

Attachment F - Call Center Resources

UNITED WAY 211 - Minnesota Call Centers:

211 is a statewide service that connects Minnesotans to social services and other resources in their local communities. 211 is free, confidential, and available via phone, text or website, 24/7/365, in 100+ languages. Residents of all 87 counties and 11 tribal nations can access information about community resources by dialing 211 or 1-800-543-7709. Depending on which area of the state someone calls from, their call will be answered by one of four 211 contact centers operating in Minnesota. See the list below for the contact center responsible for covering the county or tribal community. View details at About 2-1-1 – United Way 211_ <https://www.211unitedway.org/about-211/>

Consider connecting with the Point of Contact (POC) at the local 211 to discuss the potential for activating 211 as a partner for disaster response and recovery efforts. Perhaps sign an MOU in advance of a local emergency.

FIRST CALL 211 - Grand Rapids, MN

[First Call 211](http://www.firstcall211.net/) <http://www.firstcall211.net/>

Call 2-1-1 from service area

(218) 326-8565 Alternative Number

(800) 442-8565 Alternative Number for cell phone users

Text your zip code to 898-211 (Standard messaging and data rates may apply)

Serves the following Minnesota counties: Aitkin, Beltrami, Cass, Clearwater, Itasca, Koochiching and Lake of the Woods

Serves the following Minnesota Anishinaabe Communities:

- Parts of Bois Forte Band of Chippewa (Koochiching and St. Louis counties)

- Parts of Leech Lake Band of Ojibwe (Beltrami, Cass, Hubbard, and Itasca counties)

- Red Lake Nation (Beltrami and Clearwater counties)

- Parts of White Earth Nation (Becker, Clearwater, and Mahnommen counties)

First Call POC – (218) 326-8565

FIRSTLINK 211 – Fargo, ND

[Firstlink 211](http://www.myfirstlink.org/) <http://www.myfirstlink.org/>

Call 2-1-1 from service area

(701) 235-7335 Alternative Number

(701) 293-6462 Voicemail

Text your zip code to 898-211 (Standard messaging and data rates may apply)

Serves the following Minnesota county: Clay County

Firstlink POC - (701) 235-7335

GREAT RIVERS 2-1-1 – La Crosse, WI

[Great Rivers 211](http://www.greatrivers211.org/) <http://www.greatrivers211.org/>

Call 2-1-1 from service area

(800) 362-8255 Alternative Number

Text your zip code to 898-211 (Standard messaging and data rates may apply)

Texting is available weekday afternoons and evenings

Serves the following Minnesota counties: Fillmore, Houston, and Winona

Great Rivers POC – (608) 775-6328

GREATER TWIN CITIES UNITED WAY 211 – (GTCUW) Minneapolis, MN

GTCUW 211 <http://www.211unitedway.org/>

Call 2-1-1 from service area

(651) 291-0211 Alternative Number

(800) 543-7709 Toll Free Number

Text your zip code to 898-211 (Standard messaging and data rates may apply)

Serves the following Minnesota counties: Anoka, Becker, Benton, Big Stone, Blue Earth, Brown, Carlton, Carver, Chippewa, Chisago, Cook, Cottonwood, Crow Wing, Dakota, Dodge, Douglas, Faribault, Freeborn, Goodhue, Grant, Hennepin, Hubbard, Isanti, Jackson, Kanabec, Kandiyohi, Kittson, Lac Qui Parle, Lake, Le Sueur, Lincoln, Lyon, Mahnommen, Marshall, Martin, McLeod, Meeker, Mille Lacs, Morrison, Mower, Murray, Nicollet, Nobles, Norman, Olmsted, Otter Tail, Pennington, Pine, Pipestone, Polk, Pope, Ramsey, Red Lake, Redwood, Renville, Rice, Rock, Roseau, Saint Louis, Scott, Sherburne, Sibley, Stearns, Steele, Stevens, Swift, Todd, Traverse, Wabasha, Wadena, Waseca, Washington, Watonwan, Wilkin, Wright and Yellow Medicine

Serves the following Tribal Nations.

Anishinaabe Communities:

Parts of Bois Forte Band of Chippewa (Koochiching and St. Louis counties)

Fond du Lac Band of Lake Superior Chippewa (Carlton, St. Louis counties)

Grand Portage Band of Lake Superior Chippewa (Cook County)

Parts of Leech Lake Band of Ojibwe (Beltrami, Cass, Hubbard, and Itasca counties)

Mille Lacs Band of Ojibwe (Mille Lacs County)

Parts of White Earth Nation (Becker, Clearwater, and Mahnommen counties)

Dakota/Sioux Communities:

Lower Sioux Indian Community (Redwood County)

Prairie Island Indian Community (Goodhue County)

Shakopee Mdewakanton Sioux Community (Scott County)

Upper Sioux Community (Yellow Medicine County)

GTCUW POC - (612) 340-7496

Attachment G – FEMA 10-Point Volunteer and Donation Management Strategies

NATIONAL VOLUNTEER & DONATIONS MANAGEMENT STRATEGY INITIAL 10 KEY ELEMENTS

- 1. DONATIONS ACTIVITIES MAY BEGIN BEFORE A DISASTER DECLARATION:**
Donations and volunteers may flow into a disaster area immediately after a disaster. It is imperative that efforts are made to coordinate these early efforts to prevent difficult problems and misunderstandings later. Donations planning, coordination, and management are necessary to avoid the chaos, waste of time, and effort that large shipments of undesignated goods can cause. This is also necessary toward addressing spontaneous, unaffiliated volunteers who often arrive on-site at a disaster ready to help. Because they are not associated with any part of the existing emergency management response system, their offers of help are often underutilized and even problematic to professional responders
- 2. DONATIONS MANAGEMENT SHOULD ADDRESS UNDESIGNATED GOODS AND UNAFFILIATED “SPONTANEOUS” VOLUNTEERS:** State and Federal donations management concerns and efforts are the **unsolicited or undesignated** goods and **unaffiliated (spontaneous or convergent) volunteers**. Designated goods and services are not addressed by the national strategy; they are managed by voluntary organizations, as designated goods are part of a voluntary organization's supply line and designated volunteers are affiliated with an organization. Unaffiliated volunteer efforts should be carefully monitored to ensure that there are no health or safety issues associated with the volunteer services.
- 3. SHIPMENT OF DESIGNATED GOODS MAY BE AFFECTED BY STATE POLICIES:** During a catastrophic disaster, the State may set policies that affect the transportation of all vehicles including shipments of designated donated goods. These policies should facilitate, and not interfere with, the shipment of designated goods.
- 4. STATE AND LOCAL GOVERNMENTS ARE IN CHARGE OF DONATIONS OPERATIONS:** The government should address critical issues, such as what procedures should be established at weigh stations, toll booths, and other points of entry. The government also should address developing and disseminating a message to the public regarding donated goods and volunteer services.
- 5. FEDERAL GOVERNMENT AND NATIONAL VOLUNTARY ORGANIZATIONS ACTIVE IN DISASTER (NVOAD) HAVE SUPPORT ROLES:** NVOAD is a coalition of disaster relief agencies in the United States founded in 1969 after Hurricane Camille. Its mission is to foster cooperation, coordination, collaboration, and communication among voluntary organizations. It provides guidance to Voluntary Organizations Active in Disaster (VOAD), a State-level coalition of disaster relief agencies. The NVOAD works together with FEMA in a supporting role to State and local governments and State VOADs.
- 6. STATE SHOULD MAKE FULL USE OF EXISTING VOLUNTARY ORGANIZATION CAPABILITIES:** State and local donations management personnel should be very familiar with the strengths and interests of the voluntary organizations in their area. Disaster voluntary organizations, community-based organizations, and other non-governmental organizations have a wide variety of abilities that can be used during a disaster. Experienced voluntary organizations are often the best judges of what donated goods and volunteer services may be needed in the disaster area. Voluntary organizations are very concerned with making full use of

potential donated goods and services and in developing a good rapport with donors, in case of future disasters.

7. **USE A FLEXIBLE STRATEGY:** Flexibility must always be used in disaster operations. There is no single correct way to manage unsolicited goods and spontaneous volunteers for all disasters. The approach taken will depend on the size of the disaster and the kinds of needs in the affected community. Other factors determining the appropriate approach will depend on the types of working relationships and agreements that are made between government emergency management personnel and voluntary organizations prior to a disaster.
8. **USE A TEAM APPROACH:** While the government is responsible for certain critical issues. The leading voluntary organization representatives are actively involved in the day-to-day operations.
9. **CASH DONATIONS TO VOLUNTARY ORGANIZATIONS ARE PREFERRED:** Cash donations to the voluntary organizations experienced in disaster relief help the agencies purchase precisely what the affected community needs, such as food items for the food bank. Cash donation to voluntary organizations help the local economy affected by the disaster because the money is spent in the local area. Cash donations also eliminate the difficult transportation and logistics requirements necessary for the donation of goods.
10. **INFORMATION MANAGEMENT IS ESSENTIAL:** During a large -scale or catastrophic disaster, several thousand calls to a phone bank (hotline) can be anticipated. A phone bank is the backbone of a successful donations management operation. The public should know where to call to discuss and coordinate their offers before they collect and send goods and volunteers into the disaster area. A volunteer and donations phone bank must be adequately staffed to give the caller accurate and timely information about the need for donations of goods and volunteers.

PRINCIPLES OF MANAGING UNAFFILIATED VOLUNTEERS

1. **VOLUNTEERING AND COMMUNITY LIFE:** Volunteering is a valuable part of every healthy community. Volunteers come from all segments of society and often provide essential services. Everyone has the potential to contribute strength and resources in times of emergency.
2. **THE VALUE OF AFFILIATION:** Ideally, all volunteers should be affiliated with an established organization and trained for specific disaster response activities. However, the spontaneous nature of individual volunteering is inevitable; therefore it must be anticipated, planned for, and managed.
3. **VOLUNTEER INVOLVEMENT IN THE FOUR PHASES:** There are valuable and appropriate roles for unaffiliated spontaneous volunteers in mitigation, preparedness, response, and recovery – as well as in other areas of community need. The response phase provides an opportunity to direct volunteers toward longer-term affiliation and community involvement.
4. **MANAGEMENT SYSTEMS:** Volunteers are a valuable resource when they are trained, assigned, and supervised within established emergency management systems. Similar to donations management, and essential element of every emergency management plan is the clear designation of responsibility for the on-site coordination of unaffiliated volunteers.
5. **SHARED RESPONSIBILITY:** The mobilization, management, and support of volunteers is primarily a responsibility of local government and the nonprofit sector agencies, with support from the state level. Specialized planning, information sharing, and a management structure are necessary to coordinate efforts and maximize the benefits of volunteer involvement.

6. **VOLUNTEER EXPECTATIONS:** Volunteers are successful participants in emergency management systems when they are flexible, self-sufficient, aware of risks, and willing to be coordinated by local emergency management experts. Volunteers must accept the obligation to “do no harm.”
7. **THE IMPACT ON VOLUNTEERS:** The priority of volunteer activity is assistance to others. When this spontaneous activity is well managed, it also positively affects the volunteers themselves and thus contributes to the healing process of both individuals and the larger community.
8. **BUILD ON EXISTING CAPACITY:** All communities include individuals and organizations that know how to mobilize and involve volunteers effectively. Emergency management experts and VOAD partners are encouraged to identify and utilize all existing capacity for integrating unaffiliated volunteers.
9. **INFORMATION MANAGEMENT:** Clear, consistent, and timely communication is essential to successful management of unaffiliated volunteers. A variety of opportunities and messages should be utilized in order to educate the public, minimize confusion, and clarify expectations.
10. **CONSISTENT TERMINOLOGY:** When referring to volunteer involvement in emergency management, it is helpful to use consistent terminology. The following terms and definitions are recommended:
 - Affiliated volunteers* are attached to a recognized voluntary or nonprofit organization and are trained for specific disaster response activities. Their relationship with the organization precedes the immediate disaster, and are invited by the organization to become involved in a particular aspect of emergency management.
 - Unaffiliated volunteers* are not a part of a recognized voluntary organization and often have no formal training in emergency response. They are not officially invited to become involved but are motivated by a sudden desire to help others in times of trouble. They come with a variety of skills. They may come from within the affected area or from outside the area. (They are also known as: convergent, emergent, walk-in, or spontaneous.)

Source: FEMA, May 2013

Attachment H – Sample Volunteer Reception Center Floor Plan

Volunteer Reception Center Floor Plan

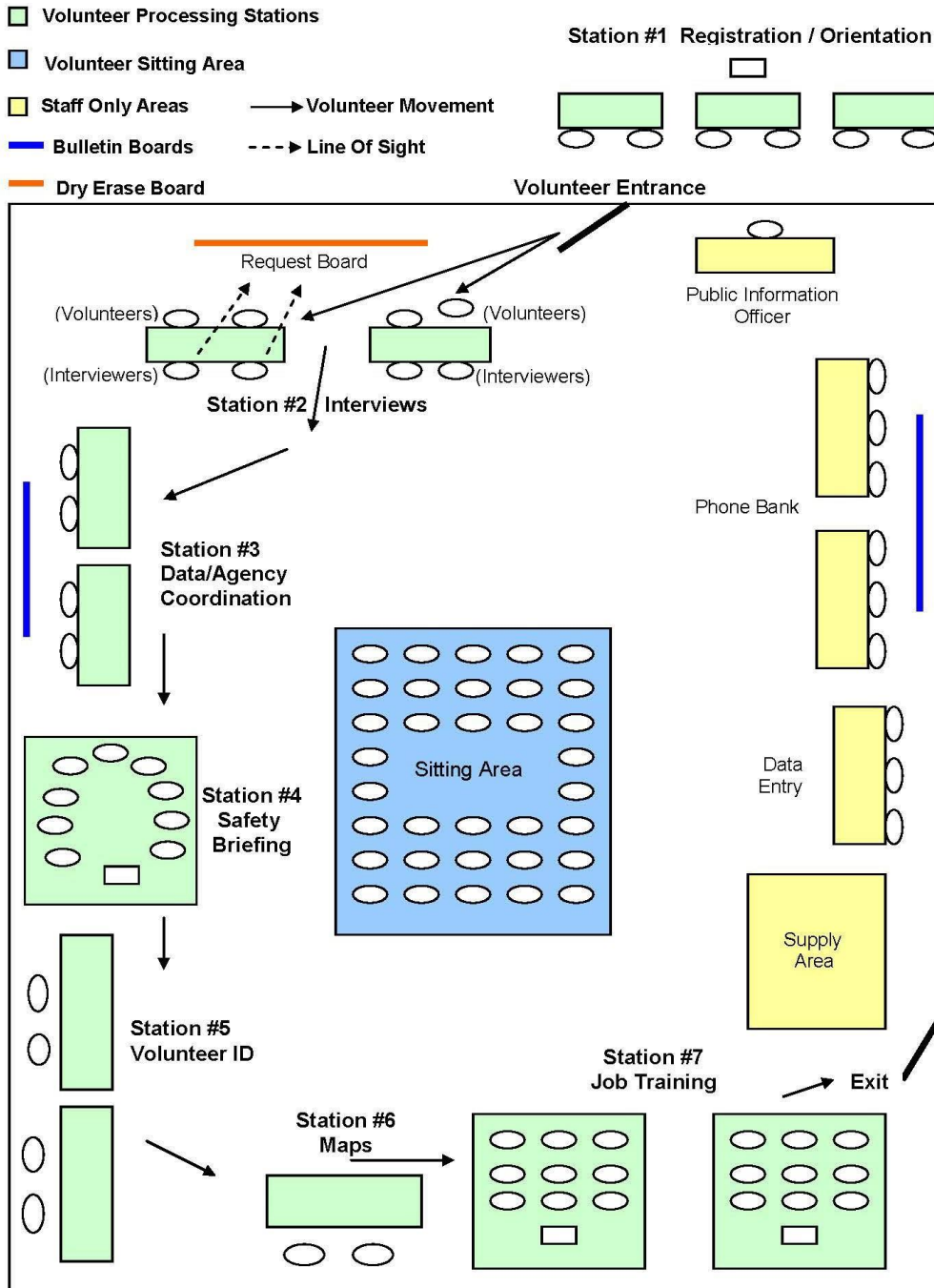

© 2000 Volunteer Florida, www.volunteerflorida.org

**Attachment I -
Donated Goods - Category Numbering List**

(Courtesy of Adventist Community Services Disaster Relief)

This numbering system is used by Adventist Community Services Disaster Relief warehousing staff to categorize and organize incoming unsolicited donated goods. Consider contacting their Minnesota Disaster Relief Coordinator, Les Morrison, at leslie.morrison@mnsda.com or 612-296-2716 to learn more or discuss signing an MOU in advance of a disaster.

Please feel free to adopt this list as the goods numbering system and to make additions or changes as necessary to fit the situation. Once adopted, share with all collection centers, warehouses and distribution centers that are established. Make sure that all facilities are using the same version of the list to avoid confusion.

Animal Products

- 010 Bird Food
- 020 Cat Food
- 022 Cat Litter
- 024 Cat Care Items
- 030 Dog Food
- 032 Dog Bones
- 034 Dog Care Items
- 042 Horse Care Items
- 052 Collars
- 054 Leashes
- 056 Kennels
- 060 Misc. Animal Food
- 062 Misc. Animal Care Items

Food – Nonperishable

- 100 Food Box
- 102 Shelf Stable Meals
- 104 Meals
- 110 Canned Fruits
- 112 Canned Vegetables
- 114 Canned Beans/Chili
- 116 Canned Meats/Fish
- 118 Canned Pasta/Noodles
- 120 Canned Soup
- 122 Sauces/Gravies
- 130 Dried Foods
- 132 Cereals
- 134 Dry Pasta
- 136 Dry Beans
- 138 Rice
- 140 Peanut Butter
- 141 Peanut Butter & Jelly Mix

- 142 Jelly/Jam/Preserve/Honey
- 144 Snacks/Crackers/Chips/Bars/Candy
- 150 Salad Dressing/Marinade
- 152 Oils/Shortening
- 154 Sugar/Sweeteners
- 156 Condiments
- 158 Seasonings
- 159 Mixed Nonperishable Foods

Drink

- 160 Juices
- 162 Coffees
- 164 Teas
- 166 Soft/Sport/Energy Drinks
- 170 Canned Milks
- 172 Dried Milk
- 174 High Protein Drinks/Ensure
- 180 Water Smaller Than 1 Gal.
- 182 Water 1 Gallon
- 184 Water 2.5 Gallons
- 186 Water 5 Gallons

Food – Perishable

- 190 Produce

Personal Care Products

- 200 Personal Care Kits
- 202 Toothbrushes/Toothpaste
- 204 Mouthwash
- 206 Body Soap/Wash/Cleaners
- 210 Shampoo/Conditioner
- 212 Hair Combs/Brushes/Accessories
- 214 Grooming Prod. Clippers/File/Tweezers
- 216 Deodorant

- 218 Razor/Shaving Cream
- 220 Feminine Hygiene Products
- 222 Lotions/Powders
- 224 Personal Wipes
- 230 Denture Products
- 240 Sun Glasses
- 242 Skin Protection Sun Block/
Screen/Ointment

Pharmaceuticals

- 250 First Aid Kits
- 252 First Aid Supplies
- 262 Adult Prescription Pharmaceuticals
- 263 Adult OTC Pharmaceuticals
- 264 Baby/Child Prescription
Pharmaceuticals
- 265 Baby/Child OTC Pharm.
- 270 Adult Diapers
- 272 Adult Care/Protective Chair/Bed Liners
Disposable

Personal Safety

- 282 Gloves
- 284 Respiratory PPE
- 286 Eye Protection/Goggles/Shields
- 288 Coveralls

Disposables

- 310 Plates Disposable
- 312 Bowls Disposable
- 314 Cups Disposable
- 316 Plastic Ware/Forks/Spoons/Knives
- 318 Paper Towels
- 320 Napkins Disposable
- 330 Facial Tissues
- 332 Toilet Paper
- 340 Table Cover/Place Mat Disposable
- 342 Cooking Items/Cup Cake Paper, etc.
- 350 Sandwich/Freezer Bags
- 352 Trash/Garbage Bags
- 354 Food Wrap Aluminum/Plastic/Wax

Baby/Child Products

- 400 Baby Kit
- 402 Diaper Bags
- 404 Diapers Disposable
- 406 Diapers Cloth
- 410 Baby Wipes
- 412 Baby Wash/Soap/Shampoo
- 414 Baby Powder/Lotion/Oint.
- 420 Baby Clothing

- 422 Baby Outerwear
- 424 Baby Blankets
- 430 Nursing Pads
- 440 Baby Food
- 442 Baby Formula
- 444 PediaSure
- 446 PediaLyte
- 448 Baby Juice
- 450 Baby Water
- 460 Baby Bottles/Sippy Cups/Feeding Items
- 462 Pacifiers/Rattles/Play Items
- 470 Training Pants/Pull Ups
- 480 Children's Disaster Kits
- 482 Games/Puzzles/Crafts
- 484 Stuffed "Plush" Toys
- 486 Toys Cars/Trucks./Boats
- 490 School Kits
- 492 School Supplies

Linens – Bedroom

- 500 Bedroom Kits
- 510 Sheets Twin
- 512 Sheets Double
- 514 Sheets Queen
- 516 Sheets King
- 520 Pillow Case Regular
- 522 Pillow Case King
- 524 Pillow NEW
- 530 Blanket/Spread NEW
- 532 Throws/Afghans
- 534 Bed Liner/Mattress Pad

Linens – Bathroom

- 550 Bathroom Kits
- 560 Towel Wash Cloth NEW
- 562 Towel Hand NEW
- 564 Towel Bath NEW
- 570 Shower Curtains
- 572 Bath Rug/Toilet Cover etc.

Linens – Misc.

- 584 Curtains

Kitchen Products

- 600 Disaster Cooking Kits
- 610 Kitchen Start-up Kits
- 612 Plates
- 614 Bowls
- 616 Cups/Glasses
- 618 Flatware Fork/Spoon/Knife
- 620 Serving Platters/Containers

- 622 Kitchen Serving Utensils
- 630 Pots/Pans
- 632 Cooking Accessories
- 634 Food Storage Containers
- 636 Water Filter/Purifier/Bottle
- 640 Towel Kitchen NEW

Cleaning Supplies

- 700 Household Kits
- 705 Clean Up Kits
- 710 Flood Buckets
- 720 Detergents Laundry/Dish
- 722 Cleaners/Disinfectants/
Sanitizers/Deodorizers
- 723 Outdoor Cleaners
- 724 Bleach/Oxy Clean
- 726 Cleaning Rag/Towel/Wipes
- 728 Sponges/Scrubbers
- 730 Gloves
- 732 Dust Masks
- 740 Trash Cans/Waste Baskets
- 742 Buckets/Pails
- 744 Mops/Brooms/Dust Pans
- 746 Floor Care Products
- 750 Clothes Line/Pins

Household – Misc.

- 760 Flashlights
- 762 Batteries
- 764 Candles
- 766 Umbrellas/Ponchos
- 768 Back Packs/Totes
- 770 Boxes
- 772 Tape Packing/Strapping
- 790 Misc. Household

Clothing/Outerwear

- 800 Clothing Packs
- 810 Clothing Men/Boys

- 812 Outerwear Men/Boys Sweater/Jackets
- 820 Clothing Women/Girls
- 822 Outerwear Women/Girls
Sweater/Jackets
- 830 Underwear Men/Boys NEW
- 832 Underwear Women/Girls NEW
- 840 Socks Men/Boys NEW
- 842 Socks Women/Girls NEW
- 850 Footwear Men/Boys NEW
- 852 Footwear Women/Girls NEW
- 860 Accessories Men
- 862 Accessories Women
- 870 Hats/Visors
- 880 Sewing Kits
- 882 Sewing Supplies

Outdoor Products

- 900 Evacuation Kits
- 910 Camping Tents/Sleeping Bags/Chairs
- 912 Camping Stove/Grill/Fuel/Charcoal
- 914 Portable Toilet
- 916 Coolers
- 918 Storage Containers
- 920 Pest Control Spray/
Repellent/Traps/Netting
- 930 Garden Tools Shovels/Rakes/Axes
- 940 Hand Tool Saw/Hammer etc.
- 950 Tarps
- 952 Plastic Sheeting
- 960 Paint Supplies Rollers/Trays/Brushes
- 964 Tape Duct/Masking/Electric
- 970 Ladders
- 980 Generators
- 982 Fuel Containers

Miscellaneous

- 995 Gift Cards/Certificates
- 998 Un-distributable Non-clothing
Donations

Attachment J - Excess Donated Material Goods Distribution Resources

List of possible places to direct the extra-donated material goods.
Please note that this is not an endorsement of any specific nonprofit or organization.

Local Unmet Needs

Consult with Long-Term Recovery Groups regarding items that they can use for unmet needs

Food and Beverages

Contact the personnel at the local food shelf. Most food is usable beyond the “best if used by date.” View [Food Safety Gov](#) for more information. Some food shelves may accept other items such as toilet paper, diapers, and cleaning supplies. Visit [Hunger Solutions](#) to find a food shelf or other hunger-relief program in the area. Consider contacting the Feeding Minnesota Senior District Manager for guidance at [Second Harvest Heartland](#). Consult with the local Environmental Agency about composting or disposal of unusable food products. Websites: <https://www.foodsafety.gov/> <http://www.hungersolutions.org/> <https://www.2harvest.org/>

Repurpose Items

Call United Way’s 211 for a list of organizations in the area that accept material goods. Some organizations may accept broken or damaged items, used clothing, shoes, etc.

Other options include:

- [Disabled American Veterans of Minnesota](https://www.donatedavmn.org/) at <https://www.donatedavmn.org/> for information
- [Goodwill](http://www.goodwilleasterseals.org/donate/how-donate-items) locations listed at www.goodwilleasterseals.org/donate/how-donate-items
- [PCs for People](https://www.pcsforpeople.org/) focuses on computers and accessories. Drop off locations are in Mankato and St. Paul. They can pick-up 15+ items but there may be a processing fee for some items. More information is posted at <https://www.pcsforpeople.org/>
- [Repowered-Electronics Recycling](https://getrepowered.org/certified-recycling/items-we-recycle/) will accept a variety of working and broken technology. They have drop-off locations in the Minneapolis and St. Paul area. Repowered will pick up items in the metro area for a fee. Review information at <https://getrepowered.org/certified-recycling/items-we-recycle/>

Post Items Online (a few options are listed)

[Donate Good Stuff](https://www.donategoodstuff.org/) <https://www.donategoodstuff.org/>

Donate Good Stuff matches usable items with the Minnesota nonprofits that need them.

[Freecycle](https://www.freecycle.org/) <https://www.freecycle.org/>

The Freecycle Network is about reuse and keeping good stuff out of landfills. Membership is free. To sign up, find the community by entering it into the search box above or by clicking on 'Browse Groups' above the search box.

[Minnesota Materials Exchange](https://mnexchange.org/) <https://mnexchange.org/>

The Minnesota Materials Exchange is a free service. Operated as part of the Minnesota Technical Assistance Program at the U of MN.

UNITED WAY 211

- Call 211 from anywhere in the state. Free, confidential, and serves 100+ languages
- Text the zip code to 898-211 (Standard messaging and data rates may apply)
- Available 24/7/365 (24 hours per day, 7 days per week, every day of the year)
- Provides health and human services information for people in Minnesota. Topics include: Animal Services, Childcare, Donations, Employment, Financial Assistance Programs, Food, Health Care, Housing/Shelter, Material Goods, Mental Health, School/Education, Transportation, Utilities, and many more. List of 211 centers is in Attachment F.

Attachment K -

Donation Information: Crowdfunding and Software

Crowdfunding is a popular and fast way to obtain financial contributions. Consult with the city, county or tribal attorney about the possibility of doing this and appropriate methods for distributing and accounting for funds. Research and determine the crowdfunding platform to use. The Public Information Officer can pre-write potential appeals and prepare photos.

Administrative fees may be charged, the rate depends upon the crowdfunding platform that is chosen. It is important to keep the cost of these fees in mind when setting the goal amount.

Consider discouraging others from establishing their own crowdfunding effort. If someone else is the “owner” of a donation page focused on a specific disaster event or long-term recovery effort, they are not accountable to forward all the money to the local community. It is encouraged to appoint someone to monitor on-line fraudulent fundraising efforts and contact all owners of crowdfunding efforts.

Please note that this is not an endorsement of any specific organization or company.

Crowdfunding - Many platforms are available. Below are a couple options:

GiveMN <https://www.givemn.org/>

Give MN is a nonprofit organization. They serve as a hub for donors to direct funds to specific organizations and causes year-round. Consider pre-registering and activate the account as needed. They do charge an administrative fee, please view their website for details. They may lower or waive the fee for disaster response.

GoFundMe <https://www.gofundme.com/>

Go Fund Me will automatically deduct a fee from each donation received. In addition, when the “owner” registers the donation page, a payment processing account will be set up. When money is withdrawn through the account, a fee of plus a surcharge will be administered.

VOLUNTEER AND DONATION MANAGEMENT SOFTWARE

There are many options for managing volunteers and donations. Check with the local Volunteer Manager or Coordinator about the system that they use. Some fundraising platforms or human resource systems can add a volunteer management or in-kind donation coordination unit; consult with the local Financial Development Manager.

Many other platforms are available. There may be a fee to obtain access to the system and a yearly maintenance cost. An internet cloud-based platform may be helpful when connecting multiple service locations.

Volunteers and donations can also be tracked on a spreadsheet, such as Microsoft Excel or Sharepoint – forms, or using pen and paper.

Volunteer Only Platforms:

Get Connected by Galaxy Digital_ <https://www.galaxydigital.com/volunteer-management-software>

SignUp sheets for volunteer scheduling <https://signup.com/>

Volgistics - Volunteer Management Software <https://www.volgistics.com/>

Fundraising Platforms which can add a Volunteer unit:

Volunteer Impact - Volunteer Management Software <https://www.betterimpact.com/volunteer-impact-volunteer-management-software/>

Attachment L - Volunteer Recruitment Resources

Find volunteers by posting the open positions on these regional websites or at volunteer centers throughout the state. Consult with the local city/county/tribal Volunteer Manager or Coordinator about posting one-time, short-term or ongoing positions and internships on these sites. It is easy to register the agency in advance and then activate positions as needed.

Please note that this list is not an endorsement of any specific recruitment site.

MNVOAD:

Post items on their DART website, contact MNVOAD for details

Central:

[United Way of Central Minnesota](https://getconnected.unitedwayhelps.org/) - Located in St. Cloud. <https://getconnected.unitedwayhelps.org/>

[United Way of West Central Minnesota](http://liveunitedwcm.galaxydigital.com/) - Located in Willmar. <http://liveunitedwcm.galaxydigital.com/>

Northeast:

[Head of the Lakes United Way](http://volunteerduluth.galaxydigital.com/) – Located in Duluth. <http://volunteerduluth.galaxydigital.com/>

[Eldercircle Volunteer Service](https://www.eldercircle.org/volunteer-service/) - Located in Grand Rapids. Serves Itasca and Koochiching counties.

<https://www.eldercircle.org/volunteer-service/>

[Volunteer Services of Carlton County](http://vscci.com/) - Located in Cloquet. <http://vscci.com/>

[Northland Volunteer Center](https://www.aeo.org/volunteer-opportunities-overview) - Located in Virginia. Serves St. Louis, Cook and Lake counties.

<https://www.aeo.org/volunteer-opportunities-overview>

Northwest:

[FirstLink - Get Involved](https://myfirstlink.org/get-involved/) - Located in Fargo, serving Fargo/Moorhead area.

<https://myfirstlink.org/get-involved/>

[United Way of Douglas & Pope Counties](http://uwdp.galaxydigital.com/) - Located in Alexandria. <http://uwdp.galaxydigital.com/>

Southern:

[United Way of Olmsted County](https://www.uwolmsted.org/volunteer-portal-information) - Located in Rochester.

<https://www.uwolmsted.org/volunteer-portal-information>

[Greater Mankato Area United Way](http://getconnected.mankatounitedway.org/) – Located in Mankato. <http://getconnected.mankatounitedway.org/>

Twin Cities Metro:

[HandsOn Twin Cities](https://www.handsontwincities.org/) – Serves the Minneapolis/St. Paul metro area. <https://www.handsontwincities.org/>

[Community Thread](https://www.communitythreadconnect.org/) - Located in Stillwater, serving the St. Croix River Valley.

<https://www.communitythreadconnect.org/>

Statewide: Their local affiliates may promote the volunteer opportunities.

RSVP - Retired Senior Volunteer Program will post opportunities for volunteers aged 55+.

<http://www.mnseniorcorps.org/volunteering/how/rsvp.aspx>

United Ways of Minnesota - <https://www.unitedwaysofminnesota.org/local-united-ways/>

College/University Websites:

Handshake - Numerous public and private universities. <https://app.joinhandshake.com/login>

Minnesota State Career Hub - 14 state colleges. <https://www.collegecentral.com/msch/>

For other schools, visit their Career or Internship Services department for information.

Other Websites:

VolunteerMatch is a free site to post volunteer opportunities. <https://www.volunteermatch.org/>

Attachment M - Volunteer Management and Recognition Resources

Volunteer Management

Contact the local city/county/tribal Volunteer Manager or Coordinator for assistance. Please note that this is not an endorsement of any specific organization or company.

[Minnesota Alliance for Volunteer Advancement \(MAVA\)](https://mavanetwork.org/) - <https://mavanetwork.org/>

MAVA connects, educates, strengthens and advocates for volunteer engagement leaders and their organizations to positively impact communities. MAVA offers a variety of trainings, networking opportunities, and an annual conference. Membership is available.

[Energize: Volunteer Management Resources](https://www.energizeinc.com/) - Offers a variety of information, including ideas for recognition. <https://www.energizeinc.com/>

[Engage Journal](https://engagejournal.org/) – Is a quarterly online journal serves volunteer managers as "the global voice of leaders of volunteer engagement". Membership is required for full access to content and the Engage Library of past publications; some content available at no cost. <https://engagejournal.org/>

[Idealist](https://www.idealists.org/en/) - Interactive website providing opportunities for exchanging resources and ideas and locating opportunities and supporters. Internships can be posted. <https://www.idealists.org/en/>

[Points of Light](https://www.pointsoflight.org/) - Website for the organization, providing research, analysis, tools, training for volunteer managers, appreciation ideas, and a yearly conference. <https://www.pointsoflight.org/>

[The Learning Center](https://learn.volunteermatch.org/) - Volunteer Match offers a variety of resources regarding volunteer recruitment and management. <https://learn.volunteermatch.org/>

Recognition Options

- Many websites include information regarding Volunteer Recognition
- The local Volunteer Manager or Coordinator may have appreciation tools available
- There are many low-cost or free options to show admiration of their efforts
- It is beneficial to verbally acknowledge and thank volunteers whenever they assist. A “Hello, thank you” and smile will help to energize the volunteers
- It is encouraged to mail a personal note, if possible. Handwritten thank you notes, cards or artwork created by the people affected by the disaster may be forwarded (with their permission) to individuals, groups, organizations, businesses and others who have donated or volunteered
- Consider distributing a public message via the Public Information Officer. The message could feature photos or video of the volunteers in action with an image of the result of their actions
- Proclamation of Gratitude from local officials can be considered

April is Global Volunteer Month with a National Volunteer Week. Ponder making an extra effort to let volunteers know that they are valued. Consider taking a few moments to communicate with the highly regarded helpers who contribute to the accomplishment of the mission.

Thank **you** for your positive interaction with volunteers, too!

Attachment N – VADM Template Plan (*alter to fit the needs of the jurisdiction*)

SAMPLE COUNTY/CITY OF ANYPLACE
EMERGENCY OPERATIONS PLAN
ANNEX TBD – VOLUNTEER AND DONATION MANAGEMENT
ESF #6

I. MNWALK REQUIREMENTS

Item #: 9 and 10

II. PURPOSE

The purpose of this annex is to explain the responsibilities for coordinating volunteers, donated goods, and financial contributions whether solicited or unsolicited, in the event of a natural, human caused, or technological disaster.

III. SITUATIONS AND ASSUMPTIONS

Disaster incidents may create a need to coordinate volunteers, donation of goods and services, and financial contributions.

A. Situations

1. A united and cooperative effort by local, state, and federal government; tribal nations; public, private, and faith-based voluntary organizations; private and nonprofit sector; and the donor community is necessary for the successful management of volunteers, donated goods and services, and financial contributions. This plan outlines a system for managing the onslaught of unaffiliated volunteers, unsolicited and non-designated goods, services, and financial contributions, which invariably make their way to the disaster area.
2. Many public and private nonprofit organizations are experienced in managing volunteers and donations and have existing capabilities to receive, process, and deliver needed goods and services to people affected by disaster (survivors). *Sample County/City of Anyplace* will collaborate with these organizations to implement the resource system. Memorandum of Understanding (MOU) will be signed with each organization and renewed on a regular basis.
3. *Sample County/City of Anyplace's* role in the allocation and distribution of donations will be limited to providing a means to coordinate response needs with offers of volunteers, goods, and services. This will be accomplished through a designated Local Voluntary Agency Liaison (VAL) and a Volunteer and Donation Coordination Team.

B. Assumptions

1. In the event of a large-scale disaster, local government and voluntary organizations may need manage volunteers and receive, coordinate, and distribute donated goods, and services.
2. Unaffiliated (spontaneous) volunteers will show up at a disaster scene to offer their skills, which may or may not be helpful. Registration, training, and supervision will be required for all volunteers assisting with disaster response and recovery. Support for these volunteers may include arranging for food, restrooms, medical care, and lodging.
3. Donated goods and services may arrive without warning and without being packed appropriately. These goods and services will be documented and sorted as quickly as possible. The amount of donated goods could be sizeable, which may create problems for storage and distribution. Volunteers may assist with the sorting and distribution of these donated goods.
4. Any financial contributions made will be managed and distributed to support disaster survivors, response, and recovery operations.

IV. CONCEPT OF OPERATIONS

- A. The Emergency Operations Plan has been designed based on the National Incident Management System (NIMS) model utilizing the Incident Command System. The Command Staff includes a Legal Advisor, Public Information Officer (PIO), Liaison, and Safety Officer. The General Staff includes the Operations Coordination Section, Planning Coordination Section, Logistics Coordination Section, and Finance and Administration Coordination Section. The Command and General Staff all report to the Emergency Operations Center Manager. The Emergency Operations Center Manager is the *Sample County/City of Anyplace's* Emergency Manager. In the event where the primary impacts are health related, a unified command structure will be utilized in collaboration with the *Sample County* Public Health department. In addition to these staff positions there are Branch Directors and Branch Unit Leaders that represent the annexes of this emergency operations plan. Branch Directors and Branch Unit Leaders report to Coordination Sections, as outlined in attachment *TBD* of the Emergency Operations Plan (EOP).
- B. Volunteer and Donation Management is part of the logistics section and therefore reports directly to the Logistics Coordination Section. The Local VAL (Voluntary Agency Liaison) serves as a Branch Unit Leader and is responsible for coordination of Volunteer and Donation Management efforts and reports to the Logistics Coordination Section. The Volunteer and Donation Team Coordinator reports to the Local VAL.
- C. The Logistics Coordination Section will consult with the Local VAL regarding potential facilities to be used for volunteer and donation management. Logistics will coordinate the signing of Memorandum of Understanding with facilities prior to a disaster event and during response, as necessary.
- D. The Local VAL will serve as the main contact with MNVOAD (Minnesota Voluntary Organizations Active in Disaster) and its affiliated voluntary organizations. The Local VAL will submit a completed MNVOAD Assistance Request Form through the State Duty Officer. The Local VAL will contact the Minnesota Homeland Security and Emergency Management (HSEM) Volunteer Resources Coordinator and State Emergency Operation Center (SEOC) with other issues when needed.
- E. The order of succession for the Local VAL is as follows:
 1. Volunteer and Donation Team Coordinator
 2. Unaffiliated Volunteer Group Supervisor
 3. Donated Goods and Funds Group Supervisor

V. VOLUNTEERS

- A. Overview of Volunteer Management
 1. *Sample County* Emergency Management will encourage individuals aged 18 and older interested in volunteering services to affiliate with a recognized voluntary organization, private nonprofit organizations, faith-based or other organized group to facilitate relief activities.
 2. No attempts will be made by anyone involved in the coordination and implementation of this plan to solicit volunteers for any specific organization.
 3. *NGO Nonprofit (NGO)* will serve as the Unaffiliated Volunteer Group Supervisor and select the Volunteer Registration Unit Leader and Volunteer Team Coordination Unit Leader.
 4. The following forms will be retained for record-keeping purposes: volunteer registration, training, volunteer tracking log (hours), financial records, injury reports, facility reports, etc.

5. Positions to manage volunteer services:
 - a) Unaffiliated Volunteer Group Supervisor – reports to Volunteer and Donation Team Coordinator
 - b) Volunteer Registration Unit Leader – reports to Unaffiliated Volunteer Group Supervisor
 - c) Volunteer Team Coordination Unit Leader - reports to Unaffiliated Volunteer Group Supervisor
 - d) Volunteer Transportation Coordinator – reports to the Volunteer Team Cord. Unit Leader
 - e) Other personnel, as needed

B. Unaffiliated Volunteer Registration

1. Volunteers must be registered prior to beginning work in the disaster area or with people affected by the disaster. Unaffiliated volunteers will be directed to the Volunteer Registration Unit Leader to register as a volunteer and determine if and where their skills may be needed. Volunteers will be directed to contact *NGO* at a phone number or website designated for disaster volunteer recruitment.
2. If the call volume exceeds what is reasonable for the *NGO* office to handle internally, other options include opening a call center or activating the MOU with United Way 211.
3. The Local VAL may identify a Volunteer Reception Center (VRC) facility, depending on the disaster needs and the numbers of offers to volunteer that are received. This will be handled through the Local VAL in consultation with the Logistics Coordination Section. It is preferred that the Volunteer Reception Center be within a one-mile radius from the disaster site. The Volunteer Registration Unit Leader will serve as the Volunteer Reception Center's Manager.
4. All members of the Unaffiliated Volunteer Group section are encouraged to verbally thank the volunteers for their assistance.

C. Volunteer Work Crews

1. The Volunteer Team Coordination Unit Leader will manage the volunteer crews which will be led by team leaders. The crew may assist with debris clean up, sandbagging, etc. The Unit Leader may consult with MNVOAD about assignments using the Crisis Clean Up system.
2. A Team Leader will be required to accompany each crew that provides volunteer services. The Team Leader will provide information to crew members regarding assignments, special instructions, and emergency information. The Team Leader will be responsible for checking in and checking out all crew members and equipment that they use. It is the responsibility of the Team Leader to ensure that accurate records are kept and provided to the Volunteer Team Coordination Unit Leader (who in turn provides the information to the Unaffiliated Volunteer Group Supervisor) regarding the status of all crew members, work locations, etc.
3. Volunteers will work assigned shifts in assigned locations. Volunteers must sign in and out for each shift at the VRC. Any changes to the original assignment must be documented.
4. The Volunteer Transportation Coordinator will arrange for transportation of the volunteers from the Volunteer Reception Center (or designated site) to and from the site.
5. Volunteers are not permitted to drive themselves to or from the disaster site.
6. The Safety Officer will arrange for security of the Volunteer Reception Center or designated sites.

D. Support for Volunteers

1. Most volunteers will help for one day or shift and then leave the area. All volunteers must have access to toilets, hand-washing facilities, and first aid stations (required). The Logistics Coordination Section of the Emergency Operations Center will organize portable facilities.
2. Volunteers who assist for more than one shift will be asked to be prepared to care for themselves upon arriving at the impacted area. For some volunteers it may be necessary to arrange for lodging. Logistics will arrange for lodging when needed. *Sample County* has an MOU with several hotels, campgrounds, and resorts in the area.
3. Arrangements for feeding of volunteers and staff will be made when necessary. The Logistics Coordination Section will conduct this coordination. Shuttle service to local restaurants may be provided when needed.
4. Mass feeding may be available through a voluntary organization with a mobile kitchen. MNVOAD affiliated organization(s) may be requested to feed volunteers by the Local VAL.

E. Volunteer Recruitment and Miscellaneous

1. *Sample County* Emergency Management may ask to identify potential volunteers with specific technical skills. The Local VAL may ask MNVOAD if they have volunteers with the skills, first. The Unaffiliated Volunteer Group Supervisor will work with the Public Information Officer (PIO) to recruit these volunteers when needed
2. The Local VAL can request the MNVOAD Disaster Agency Response Technology (DART) system to be activated to coordinate volunteer requests (*Sample County/City of Anyplace*) and offers (the public).
3. Certification and credentials will be required of some volunteers with specialized skills to ensure volunteers chosen are qualified to provide the services they offer. Construction contractors providing both residential and commercial construction must be licensed by the State of Minnesota and show proof of license, insurance, and bonding. All trades, including plumbing, heating, and electrical contractors, must be licensed, bonded, and insured either by the State of Minnesota or as applicable by the local municipality.
4. Voluntary organizations involved in the disaster response may request public volunteers, through the Local VAL. Requests from the disaster affected community for public volunteers will be made through the Unaffiliated Volunteer Group Supervisor. VRC will refer the unaffiliated volunteers as appropriate. Upon referral, the organization assumes responsibility for the volunteers but must report hours to the VRC.
5. Businesses and people offering their paid services will be placed on a list and given to the Long-Term Recovery Group, if formed.
6. Thank you messages will be sent to the volunteers by the Public Information Officer. The PIO may document the efforts of volunteers with photos, video, and stories.
7. The Unaffiliated Volunteer Group Supervisor will provide an audit of the volunteer management process when demobilization occurs and participate in the After-Action Review process.
8. Documented hours donated by volunteers may be used by the *Sample County* Emergency Manager for share cost purposes.

VI. DONATED GOODS

A. Overview of Donated Goods Management

1. For the proper management of unsolicited and non-designated goods donations, operating facilities will include checkpoints, collection centers, distribution centers, and storage warehouses to be established, when needed.
2. *C-Three Nonprofit (CTN)* will serve as the Donated Goods and Funds Group Supervisor and select an Unsolicited Goods Unit Leader. The Unsolicited Goods Unit Leader may appoint Collection, Distribution and Warehouse Coordinators and other personnel, as needed.
3. All members of the Unsolicited Goods Group section are encouraged to verbally thank the donors for their contribution and volunteers who assist with the goods.
4. No attempts will be made by anyone involved in the coordination and implementation of this plan to solicit or distribute donated goods for any specific organization or individual.
5. The PIO may document the donation of goods with photos, video, and stories.

B. Donated Goods Tracking and Facilities

1. *Sample County/City of Anyplace* will follow established guidelines for tracking the receipt and distribution of unsolicited and non-designated goods. All volunteer related forms will be submitted to the Volunteer Registration Unit Leader.
2. The Safety Officer will provide coordination with local law enforcement to ensure the required twenty-four-hour security of facilities and personnel is available. Contracting with a local security firm may be an option.
3. Transportation will be arranged with local delivery companies for donated goods to flow between collection centers, warehouses, and distribution centers, as needed. Coordinate with the Logistics Section. A list of moving and storage companies can be found in the resource database which is in the Emergency Operations Center.
4. When necessary, the Local VAL will coordinate with the Unaffiliated Volunteer Group Supervisor to provide personnel to assist with collection centers, distribution centers, warehouses, and donation phone lines. MNVOAD may be able to provide support.
5. The State of Minnesota will support *Sample County/City of Anyplace* with resource requirements, as appropriate, to make facilities operable in a timely manner. This request will be made through the Emergency Operations Center to the SEOC.

C. Collection and Solicitation of Donated Goods

1. The Unsolicited Goods Unit Leader will coordinate with the Public Information Officer to publicize a list of specific items that are needed by the jurisdiction.
2. The Unsolicited Goods Unit Leader will coordinate with the Sheriff's Office, local police, and Minnesota State Patrol to identify and manage checkpoints for incoming donated goods. Weigh stations and rest areas will be considered for this use.
3. The Unsolicited Goods Unit Leader will coordinate with the Department of Transportation and the Minnesota State Patrol in directing vehicles and trucks bringing donations into the area. Road signs should be posted and clearly marked to the Collection Center locations.
4. Collection Centers are where donated goods are initially brought to be received, categorized, sorted, and processed to make them ready for distribution or storage. Critically needed donated goods are sent from the site to distribution centers to be offered to disaster survivors.
5. Donors will be advised to properly package and label all goods and to provide a detailed inventory list with shipments. No donation should be sent into the affected disaster area.

6. The Local VAL can request that the MNVOAD Disaster Agency Response Technology (DART) system to be activated to coordinate donated goods requests (*Sample County/City of Anyplace*) and offers (the public).
7. Donors may choose to send donated goods directly to voluntary organizations and local nonprofit agencies. Donors will be encouraged to make their own decision in choosing which organization the donation is to be designated to.
8. Donors who call and insist on donating unsolicited or unwanted goods will be advised that although the goods cannot be accepted at this time, the information will be entered a database and made available to human service organizations, emergency responders and government agencies, should a need arise for such goods. However, *Sample County* will plan for these items to arrive at the Collection Center.
9. The goods will be sorted at the Collection Center and sent to a Distribution Center or Warehouse.

D. Distribution and Warehousing of Donated Goods

1. Distribution Centers are where survivors receive needed goods and will be near the disaster site or survivors. The centers are stocked directly from collection centers (for critically needed supplies), and from warehouses (for other goods, as needs dictate).
2. Warehouses are where goods that will be needed in the future but are not currently necessary are stored. Warehouses should not be in or near the disaster area and goods stored in the warehouse should not be issued directly to survivors from the warehouse. When needed, goods are shipped from the warehouse to distribution centers to be given out to those in need.
3. Corporate offers of bulk items will be accepted if the items can be used in the disaster response and relief efforts. The decision as to what will be requested will be done by the Unsolicited Goods Unit Leader and communicated through the Public Information Officer.
4. Information concerning corporate offers of bulk items will be entered in the resource database.
5. Corporate donors will be advised to label all goods and to provide a detailed inventory list with all shipments. Expiration dates should be listed on all goods.
6. Thank-you messages will be sent to the donors. The Public Information Officer will provide public acknowledgement. Some donors may request a letter documenting their donation.

E. Distribution of Excess Donated Goods

1. After the response phase ends, the remaining goods will be offered to the *Sample County* Long-Term Recovery Group (when formed).
2. Remaining unneeded goods will be made available to local public, private, faith-based, and non-profit organizations. United Way 211 may assist with locating regional or other organizations to accept the remaining goods. Some organizations will accept damaged items.
3. *Sample County/City of Anyplace* Emergency Management will work with the appropriate state and federal agencies to recycle items and compost unusable food. Disposal of spoiled or unsafe items may occur.
4. Unsolicited Goods Unit Leader will audit of all donated goods and services when demobilization occurs. An accounting firm may be contracted to assist with the audit.

F. Public Memorial Site

1. *Sample County* Historical Society will establish, maintain, and decommission the public memorial site, when needed. The memorial site will not collect donated goods or funds.
2. Reports to the *Sample County* Board of Commissioners for this project.

VII. FINANCIAL CONTRIBUTIONS

A. Overview of Financial Contribution Management

1. *United Fund of Helpful Minnesota (United Fund)* will serve as the Undesignated Funds Unit Leader and appoint personnel as needed.
2. *Sample County* Emergency Management, through news releases, social media, and printed materials, will encourage financial contributions to voluntary organizations rather than donated goods or services. The Public Information Officer will coordinate any information provided to the media before being released to the public.
3. Every effort will be made by the *Sample County/City of Anyplace* to encourage the public to send financial contributions to established nonprofit disaster voluntary organizations of their choice. All inquiries concerning donations for a specified organization will be referred to that organization. The organization accepting/receiving designated donations will follow its own policies and procedures for handling the logistics involved.
4. In circumstances where the donor is undecided or is unaware of which voluntary organizations are involved in disaster relief activities, the individual responding to the inquiry may provide a list of those organizations that may accept offers.
5. No attempts will be made by anyone involved in the coordination and implementation of this plan to solicit or distribute donations for any specific organization or individual.

B. Disaster Donations Fund

1. Even after being asked not to send financial contributions (cash, check, money order, etc.) directly to the Emergency Operations Center or *Sample County*, monetary donations may be received. To prepare for that contingency, *Sample County* Emergency Management will activate the established Disaster Donations Fund through the *United Fund of Helpful Minnesota*.
2. Financial contributions received but not designated to a specified organization will be deposited in the Disaster Donations Fund account. Donors who do not wish to specify their contribution to a voluntary organization will be advised to make the donation check payable to the Disaster Donations Fund.
3. *United Fund of Helpful Minnesota* has established a *Sample County* Disaster Relief GiveMN.org account. All funds raised will be deposited into the Disaster Donation Fund.
4. Independent fundraising efforts such as fundraisers and crowdfunding organizers will be encouraged to direct their funds to the Disaster Donations Fund.
5. Fundraising fraud will be monitored by the Undesignated Funds Unit Leader and PIO. If fraud is detected, it will be immediately reported to the Donated Goods and Funds Group Supervisor, Volunteer and Donation Team Coordinator, Local VAL, and Security Officer. The Emergency Manager and *Sample County/City of Anyplace* law enforcement will act as appropriate.
6. The *United Fund of Helpful Minnesota*, the fiscal agent for this plan and the *Sample County* Long-Term Recovery Group (LTRG). *United Fund of Helpful Minnesota* may establish an on-line donation system to accept local, national, and international financial contributions.
7. The *United Fund of Helpful Minnesota* is a 501(c)3 organization. Financial contributions, therefore, are tax deductible. *United Fund* will send thank you messages to contributors. Some donors may request a letter documenting their contribution. The Public Information Officer will distribute messages thanking the donors for their contribution.

C. Distribution of Disaster Donations Fund Contributions

1. Meeting the unmet needs of survivors will be the priority for distribution of the Disaster Donations Fund. The *Sample County* Long-Term Recovery Group (LTRG), when activated, will work with a disaster case manager to verify survivor requests, and submit recommendations to *United Fund of Helpful Minnesota* who will distribute the funds.
2. The Local VAL may assign the Volunteer and Donation Coordination Team to review requests if a LTRG is not formed. They will have the responsibility of reviewing applications, preparing a summary for each application with an anonymous designation, and making recommendations. The team may consult with the Local VAL and Emergency Manager.
3. After the survivor needs are met, voluntary organizations, local faith-based and *Sample County* non-profit entities may apply for grants from the Disaster Donations Fund. It is required for the grant to be used specifically for disaster-related needs and expenses.
4. Grantees cannot use any portion of a grant for administrative expenses. Grantees will be required to submit documentation of expenditures.
5. The United Fund of Helpful MN will release undesignated funds, remaining after FEMA has closed all project applications. The *Sample County* Long-Term Recovery Group will receive the funds for future disasters. The *Sample County* Local VOAD or CERT groups may use funds for disaster preparedness and prevention efforts. Other local nonprofit organizations must demonstrate that the disaster had an adverse impact on their organization's resources.
6. The Undesignated Funds Unit Leader will ensure that an independent audit of the Disaster Donations Fund is performed by a certified accounting firm.

VIII. ORGANIZATION AND ASSIGNMENT OF RESPONSIBILITIES

A. Organization

1. The emergency organization is described in Section IV of the Basic Plan.
2. Incident Command System – Emergency Operations Center Interface
 - a) Incident Command oversees all on-scene operations. This coordination takes place at an Incident Command Post. On-scene logistics personnel will order supplies, resources, and personnel to manage the scene in accordance with Incident Action Plan.
 - b) Not all emergencies require on-scene operations or the establishment of an Incident Command Post. For those emergencies that may be over a wide area (flooding, ice storm, tornado, or winter storm) or are health-based the Command Post and Emergency Operations Center may be co-located.
 - c) A division of responsibility should be agreed upon between Incident Command and the Emergency Operations Center. Incident Command will manage operations on-scene, while the Emergency Operations Center coordinates operations beyond the incident site, taking into consideration the community at large, while supporting the Incident Action Plan developed by Incident Command.

B. Lines of Succession

1. Lines of succession for the Mayor, County Board Chair, and Emergency Manager are outlined in Annex B – Direction and Control.
2. Lines of succession for each department and agency director shall be done in accordance with operating guidelines and delegations of authority within each department.

C. Assignment of Responsibilities

Volunteer and Donation Management, as a function, occurs during throughout all phases of an emergency.

1. *Sample County* Emergency Manager

The *Sample County* Emergency Manager (or designee) is responsible for carrying out the emergency management program for *Sample County/City of Anyplace*. The Emergency Manager will activate the Emergency Operations Center as required or requested to coordinate and support the activities of all departments and organizations assisting with response and recovery efforts. The Emergency Manager will establish response and recovery priorities through the Emergency Operations Center and will coordinate the resources needed to support emergency operations.

2. Local VAL of *Sample County*

The Local Voluntary Agency Liaison (VAL) is responsible for administration of the Volunteer and Donation Management plan. The Local VAL will report to the Logistics Coordination Section. The Local VAL will assign a Volunteer and Donation Team Coordinator to implement the Volunteer and Donation Management Plan. The Local VAL will provide coordination and support to fulfill the response and recovery priorities. The Local VAL will be the main contact for MNVOAD and its members (voluntary organizations). The Local VAL or designee will attend all MNVOAD Coordination Calls for situational awareness regarding the request for services.

3. Volunteer and Donation Team Coordinator

The Volunteer and Donation Team Coordinator will assign a team composed of the Unaffiliated Volunteer Group Supervisor and the Donated Goods and Funds Group Supervisor. They will work with public, private, and faith-based representatives to determine the initial needs for volunteers, donated goods, services, and financial support. The Group Supervisor will oversee the Unit Leaders and will provide coordination as needed. The Volunteer and Donation Team Coordinator reports to the Local VAL.

4. *NGO Nonprofit (NGO)* – Unaffiliated Volunteer Group Supervisor

NGO is responsible for recruiting, assigning and following-up with volunteers supporting disaster response and recovery operations. Community members or spontaneous volunteers wanting to assist in the community will be managed by *NGO*. All volunteer efforts will be coordinated through *NGO*. *NGO* may seek assistance with the recruitment of volunteers from other sources.

a) Volunteer Registration Unit Leader

The Volunteer Registration Unit Leader will coordinate the registration of volunteers. The Volunteer Registration Unit Leader will manage the Volunteer Reception Center if one is opened.

b) Volunteer Team Coordination Unit Leader

The Volunteer Team Coordination Unit Leader will coordinate volunteer work crew teams assigned to assist with the disaster. The Volunteer Team Coordination Unit Leader will supervise the Volunteer Transportation Coordinator.

5. *C-Three Nonprofit (CTN) – Donated Goods & Funds Group Supervisor*
CTN is responsible for supervision of unsolicited donated goods, services, and undesignated financial contributions.
 - a) *Unsolicited Goods Unit Leader*
The Unsolicited Goods Unit Leader is responsible for the coordination of collecting, sorting, distributing, and storing donated goods. In addition, inventory control to support the community and disaster operations.
 - b) *United Fund of Helpful Minnesota (United Fund) – Undesignated Funds Unit Leader*
United Fund will serve as the fiscal agent for the plan and establish a Disaster Donations Fund. *United Fund* will process, provide documentation for non-designated financial contributions, and monitor for fraud. *United Fund* will distribute funds through the *Sample County* Long Term Recovery Group.
6. *Minnesota Voluntary Organizations Active in Disaster (MNVOAD) – Affiliated Volunteers*
MNVOAD is comprised of voluntary organizations that provide affiliated and trained volunteers offering a variety of specialized disaster related services. Some of these services include
 - a) MARC Multi-Agency Reception Center to aid survivors
 - b) Field Operations – Communications Team to relay messages
 - c) Crisis Clean-Up system to coordinate debris, muck-out, tree cutting, rebuilding, etc.
 - d) Local VAL of *Sample County* will be the liaison with MNVOAD and its affiliated organizations. A completed MNVOAD Assistance Request Form will be submitted by the Local VAL to the State Duty Officer and HSEM Volunteer Resources Coordinator when services are needed. The Local VAL will notify MNVOAD when the requests alter or are no longer needed.
7. *Sample County CERT Program*
The *Sample County* Community Emergency Response Team (CERT) Program is coordinated by the *Sample County* Sheriff Department. Members of the CERT Team have been trained to assist with volunteer management, goods donation management, and call center operation. They will be assigned to tasks as needed. Mutual Aid Agreement permits them to deploy to other jurisdictions when coordinated with the *Sample County* Emergency Manager.
8. *Sample County Local VOAD*
The *Sample County* Local VOAD is an independent whole community disaster preparedness coalition of local groups. During a disaster response and after registering at the Volunteer Reception Center (VRC), they may have members who can provide support for VADM efforts.
9. *Sample County Long Term Recovery Group (LTRG)*
The *Sample County* Long Term Recovery Group is an autonomous partnership of groups and case managers focused on recovery and unmet needs of survivors. During a disaster response and after registering at the VRC, the members of this group would like to focus on donated goods distribution efforts. The LTRG may provide case management and distribute funds collected by the Disaster Donation Fund and excess donated goods.
10. *Sample County Historical Society*
The *Sample County* Historical Society is a nonprofit organization which will establish, monitor, and decommission a public memorial site, when needed. The SCHS will collect all items from the memorial and distribute or retain for historical purposes. Reports to the *Sample County* Board of Commissioners for this project.

11. United Way of Minnesota

United Way provides a resource through 211, a phone number to give or get help in Minnesota. 211 is free, confidential, and available twenty-four hours a day. The PIO will be responsible for updating 211 regarding the need for volunteers and donations. An MOU has been signed so that 211 may be used to provide Call Center support and enter Crisis Clean Up requests, when needed. 211 may assist with locating organizations to accept excess donated goods.

IX. ADMINISTRATION AND SUPPORT

A. Records

1. Records will be maintained on the use of all equipment, whether owned, leased, rented, or borrowed. These records/contracts will be used as basis for possible recovery of emergency operations expenses from a responsible party or for potential reimbursement from the State or Federal Government. All records and contracts generated by the Local VAL and Volunteer and Donation Team Coordinator should be provided to the Finance and Administration Coordination Section for cost recovery and reimbursement documentation.
2. Each department, agency or service of government will provide for the maintenance of records during an emergency. These records include work hours, equipment hours, volunteer hours, supplies and materials consumed, injuries to personnel, and damage to public facilities and equipment. All records generated during an emergency will be collected and maintained in an orderly manner, so a record of actions taken is preserved for use in determining response costs, settling claims, and updating emergency plans and procedures.

B. Resources

1. Local resources can be found on file in the resource database as well as on Shared Drive - forms. Record databases for resources and contacts of each department shall be updated on a regular, scheduled basis to keep the resource database current to reflect current capabilities.
2. These resources are also to be reported to emergency management when there has been a significant change in a resource, in addition to the scheduled maintenance. *Sample County* Emergency Management maintains this schedule. These resources retain confidentiality within the Emergency Management department and sensitive information will not be released without prior approval.

C. After-Action Review

1. Following activations of the Emergency Operations Center or use of the Emergency Operations Plan, Emergency Management will coordinate a review of each annex of the Emergency Operations Plan to identify needed improvements, procedure changes, personnel and facility changes or resource needs.
2. All personnel are expected to participate in the After-Action Review.

D. Training and Exercises

1. Personnel identified in the Emergency Operations Plan and those who staff the Emergency Operations Center will receive National Incident Management System (NIMS) and Incident Command System (ICS) training. Although some personnel may receive more advanced training, everyone will receive IS-100, IS-200, and IS-700. A full list of personnel and required training can be found on file in the Emergency Management office. Personnel who staff the Emergency Operations Center shall also receive appropriate training on their role in the Emergency Operations Center and on the operations of the facility. This training will be arranged by the Emergency Management Department.

2. Emergency Management follows the Emergency Management Performance Grant (EMPG) exercise requirements to exercise and evaluate the Emergency Operations Plan. A more detailed explanation of the County/City exercise plan can be found as Attachment *TBD* of the Basic Plan.
3. The Volunteer and Donations Management Plan will be exercised on a regular basis. Elements of volunteer and donation management will be included in other drills and exercises, when possible.

X. ANNEX DEVELOPMENT AND MAINTENANCE

- A. The *Sample County/City of Anyplace* Emergency Operations Plan, including the Basic Plan and Annexes, is updated on an annual basis. Each annex representative is responsible for participating in the full review process every other year and for independently reviewing the annex on an annual basis. The overall responsibility for maintaining the Emergency Operations Plan is that of the *Sample County* Emergency Management Department.
- B. Any standard operating guidelines, personnel directories, maps, or other tools needed to support emergency operations should be developed and maintained by the responsible department. It is the department’s responsibility to ensure access to this information during times of large-scale emergency or disaster, to coordinate training for personnel regarding these procedures and to inform Emergency Management of any changes that directly impact the Emergency Operations Plan.

XI. REFERENCES

- A. League of Minnesota Cities – Volunteer Liability
- B. Minnesota Voluntary Organizations Active in Disasters (MNVOAD) Assistance Request Form and Glossary can be found on file in the Emergency Operations Center
- C. Moving and Storage Companies can be found in the Resource Database

XII. AUTHENTICATION

_____	_____
<i>Sample County</i> Emergency Manager	Date
_____	_____
<i>NGO Nonprofit</i> , Executive Director	Date
_____	_____
<i>C-Three Nonprofit</i> , Executive Director	Date
_____	_____
<i>United Fund of Helpful MN</i> , Executive Director	Date

XIII. ATTACHMENTS

1. Position Action Sheet
2. Personnel Directory
3. Documentation Forms
 - a) Volunteer Registration Form
 - b) Volunteer Tracking Form
 - c) Facility Agreement Form
 - d) Donation Offer
 - e) Donation Log
4. Donated Goods Recommendations – Facilities and Excess Item Distribution
5. Request for Volunteers Form

POSITION ACTION SHEET
VOLUNTEER AND DONATION MANAGEMENT

Activation Phase

- Check in with the Personnel Unit upon arrival at the Emergency Operations Center.
- Report to the Local VAL (Voluntary Agency Liaison) at the Logistics Coordination Section.
- Setup your workstation and review your position responsibilities.
- Establish and maintain a position log that chronologically describes your actions taken during your shift. Document your time during every phase of the emergency.
- Determine your resource needs such as a computer, phone, plan copies, and other reference documents.

Operational Phase (duties as assigned)

- Identify and prepare specific sites for volunteer and donation management facilities and begin assembling needed equipment and supplies.
- Identify and coordinate with those voluntary organizations that could aid in operating the jurisdiction's volunteer and donation management program.
- Assign responsibilities for various volunteer and donation management activities.
- Prepare a summary for elected officials, department heads, and local volunteer groups on a periodic basis about the local volunteer and donation management program.
- Set up the volunteer and donation management facilities that are activated and determine how each facility will be logistically supported.
- Staff volunteer and donation management facilities with volunteer or paid workers, conducting on-the-job training as needed.
- Ensure that volunteers have registered and receive training prior to beginning work, as appropriate.
- Collect, sort, store, distribute, and properly dispose of donated goods, if necessary.
- Ensure contingency procedures are established for rapidly activating the Disaster Donations Fund to receive financial contributions. *United Fund of Helpful MN* will serve as the fiscal agent.
- In coordination with the Public Information Officer, provide regular updates to the media on volunteer and donation procedures, progress, status, and the current needs list (volunteers, goods and services that are needed and not needed).
- Keep records of volunteers and donations received; thank volunteers and donors.
- Maintain accounts of expenses, individual work hours, etc. Volunteer and donation activities and functions are not generally reimbursable; however, if certain expenses are considered for reimbursement, accurate records will have to be submitted.
- Continually assess volunteer and donation management operations and determine when the facilities should close or be consolidated and when the volunteer and donation management program can be terminated.
- If another person is relieving you, ensure they are thoroughly briefed before you leave your workstation.

Demobilization Phase

- Deactivate your assigned position and close out logs when authorized by the Local VAL.
- Complete all required forms, reports, and other documents. All forms should be submitted to the Documentation Unit prior to your departure.
- Be prepared to provide input to the after-action report.
- Clean up your work area before you depart.
- Leave a forwarding phone number where you can be reached.

PERSONNEL DIRECTORY

Emergency Manager

Logistics Coordinator Section

Local VAL (Voluntary Agency Liaison)

Volunteer and Donation Team Coordinator

Unaffiliated Volunteer Group Supervisor

Volunteer Registration Unit Leader

Volunteer Team Unit Leader

Volunteer Transportation Coordinator

Donated Goods and Funds Group Supervisor

Undesignated Goods Unit Leader

Unsolicited Funds Unit Leader

Safety Officer

Public Information Officer

VOLUNTEER REGISTRATION FORM *Template* - Please Print Clearly

First Name	Last Name		
Address/Apt	City	State	Zipcode
Phone (circle): Home Work	Cell Phone		
Your Email Address			
Emergency Contact (EC)	EC Relationship to You		
EC Phone	EC Email		
Your Age: Age 18+ Under age 18 requires a Parental/Guardian Form	Your Gender: Female Male Other		
Are you affiliated with any Disaster Relief Voluntary Organization as a volunteer or paid staff? No Yes If yes, please list organization(s):			
Do you have any Disaster Relief training? If yes, please explain:			
Do you have any of these skills? (check all that apply)			
<input type="checkbox"/> Chainsaw Operator	<input type="checkbox"/> Heavy-Equipment Operator (backhoe, bobcat)		
<input type="checkbox"/> Chaplain/Spiritual Care	<input type="checkbox"/> Loading/Unloading (30+ lbs)		
<input type="checkbox"/> Childcare (Licensed)	<input type="checkbox"/> Medical Professional (Certified/Licensed)		
<input type="checkbox"/> Commercial Driver's License (CDL)	<input type="checkbox"/> Mental Health Professional (Licensed)		
<input type="checkbox"/> Construction/Handyperson	<input type="checkbox"/> Security		
<input type="checkbox"/> Custodial	<input type="checkbox"/> Shelter/Lodging		
<input type="checkbox"/> Data Entry/Clerical	<input type="checkbox"/> Social Worker (Licensed)		
<input type="checkbox"/> First Aid Certification (current)	<input type="checkbox"/> Sorting (donated items)		
<input type="checkbox"/> Food Preparation	<input type="checkbox"/> Warehouse Operations (stocking, inventory)		
<input type="checkbox"/> Forklift Operator	<input type="checkbox"/> CERT Team at _____.		
<input type="checkbox"/> Ham Radio Operator (Licensed)	<input type="checkbox"/> Other:		
Equipment you have with you and available to use: (with safety equipment)			
<input type="checkbox"/> Backhoe	<input type="checkbox"/> Shovels		
<input type="checkbox"/> Bobcat	<input type="checkbox"/> Trailer – Covered		
<input type="checkbox"/> Chainsaw	<input type="checkbox"/> Trailer – Flatbed		
<input type="checkbox"/> Forklift	<input type="checkbox"/> Truck – Dump		
<input type="checkbox"/> Passenger Van	<input type="checkbox"/> Truck – Pickup		
<input type="checkbox"/> Rakes	<input type="checkbox"/> Other:		
Other Skills/Equipment:			
Are willing to help in the Volunteer Reception Center? No Yes If yes, please indicate below:			
<input type="checkbox"/> Registration/Welcome	<input type="checkbox"/> Equipment (hand out rakes, etc.)		
<input type="checkbox"/> Escort	<input type="checkbox"/> Language Translation		
Language Skills: (please list)	Sign Language Skills: No Yes		
Signature	Today's Date		

**SAMPLE COUNTY EMERGENCY MANAGEMENT
VOLUNTEER TRACKING LOG**

DATE:

GROUP/TEAM	ASSIGNMENT/LOCATION	NAME (First and Last)	PHONE NUMBER and EMAIL	TIME IN	TIME OUT

**SAMPLE COUNTY EMERGENCY MANAGEMENT
FACILITY AGREEMENTS FORM**

DATE	ORGANIZATION	ADDRESS/PHONE/ CONTACT	LOCATION SITE/FACILITY	AUTHORITY CONTACTED	MISC. CONDITIONS	STATUS: OPEN/CLOSED

DONATION OFFER
DONATED GOODS AND SERVICES INTAKE FORM

Please print clearly

Call Received by: _____ Date: _____ Time: _____

NOTE: Financial contributions are the best option. Refer all financial contributions to the MNVOAD members (voluntary organization) who are responding to this disaster. Do not solicit donations for any specific organization. If the donor does not wish to contribute to an organization, refer them to the Disaster Donations Fund at *United Fund of Helpful MN*. Individual volunteers should register through *NGO Nonprofit* or the Call Center phone line/website.

Donor Name and Information:

First Name: _____ Last Name: _____

Title: _____ Organization/Company: _____

Email: _____

Phone #1: _____ Phone #2: _____

Address: _____

City: _____ State: _____ Zip: _____

County: _____

Donated (free) Goods: _____ or Services: _____

Commercial (vendor) Goods: _____ or Services: _____ (Large quantities)

Type of Resource: (e.g., people, food, clothing, household goods, equipment)

Category: (e.g., group of adult volunteers, water, child items, bedding, tables, and chairs)

Sub-Category: (e.g., construction skills, gallon-distilled, socks size 0-3, wool blankets, folding-gently used)

Description Notes:

Total Quantity: _____ Units (#): _____ Measure (e.g., each box): _____

Packaging: _____ Amount (#): _____ Size (e.g., can, dozen, gallon): _____

Palletized: Yes or No Transportation Required: Yes or No (donor is encouraged to provide)

Refrigeration Required: Yes or No Restrictions: Yes or No

Resource Location: _____

Estimated Value: _____ Available Until: _____

Follow- Up Required: Yes or No

Action Taken: _____ Inventory ID Assigned: _____

NOTE: Offers to provide paid goods or services will be given to Long-Term Recovery Group, if formed

**SAMPLE COUNTY EMERGENCY MANAGEMENT
DONATED GOODS/SERVICES LOG**

STAGING AREA: DATE: SUPERVISOR: PAGE:

DATE	ITEM	QNTY.	COST	SOURCE	CONTACT #	REC'D	QUANTITY USED	BALANCE ON HAND
1.								
2.								
3.								
4.								
5.								
6.								
7.								
8.								
9.								
10.								
11.								
12.								

DONATED GOODS RECOMMENDATIONS

Donated Goods Collection, Distribution or Warehouse Centers

Facility Recommendations

50,000 to 250,000 square feet of covered space
Electrical, water, and phone service
Equipment availability: conveyor system, forklifts, pallet jacks
First aid station
Loading dock
Location near disaster area
Location on or near major transportation routes
Parking area for volunteers/workers or shuttle service
Racks for warehousing pallets
Ramps into/out of facility
Refrigerator, freezer, and food storage area
Restroom facilities (or area where portable restrooms can be placed outdoors)
Security station
Separate entrance and exit locations
Signage
Staging area for trucks
Temperature controlled (heating and air conditioning)
Tents for pop-up goods distribution sites
Recycling bins
Compost bins (desired)
Waste disposal, dumpsters, and pickup

Additional Supplies/Equipment

Carts (two-wheel and four-wheel)
Chairs
Clipboards
Computer
Copy machine
Display boards
Fax machine
Lights
Paper
Pens
Phone(s)
Printer
Recycling baskets
Storage bins
Tables

Excess Donated Material Goods Distribution Resources

List of possible places to direct the extra-donated material goods.

Please note that this is not an endorsement of any specific nonprofit or organization.

Local Unmet Needs

Consult with Long-Term Recovery Groups regarding items that they can use for unmet needs

Food and Beverages

Contact the personnel at the local food shelf. Most food is usable beyond the “best if used by date.” View Food Safety Gov for more information. Some food shelves may accept other items such as toilet paper, diapers, and cleaning supplies. Visit Hunger Solutions to find a food shelf or other hunger-relief program in the area. Consider contacting the Feeding Minnesota Senior District Manager for guidance at Second Harvest Heartland. Consult with the local Environmental Agency about composting or disposal of unusable food products. Websites:
<https://www.foodsafety.gov/> <http://www.hungersolutions.org/> <https://www.2harvest.org/>

Repurpose Items

Call United Way’s 211 for a list of organizations in the area that accept material goods. Some organizations may accept broken or damaged items, used clothing, shoes, etc.

Other options include:

- Disabled American Veterans of Minnesota at <https://www.donatedavmn.org/> for information
- Goodwill locations listed at www.goodwilleasterseals.org/donate/how-donate-items
- [PCs for People](https://www.pcsforpeople.org/) focuses on computers and accessories. Drop off locations are in Mankato and St. Paul. They can pick-up 15+ items but there may be a processing fee for some items. More information is posted at <https://www.pcsforpeople.org/>
- Repowered-Electronics Recycling will accept a variety of working and broken technology. They have drop-off locations in the Minneapolis and St. Paul area. Repowered will pick up items in the metro area for a fee. Review information at <https://getrepowered.org/certified-recycling/items-we-recycle/>

Post Items Online (a few options are listed)

Donate Good Stuff <https://www.donategoodstuff.org/>

Donate Good Stuff matches usable items with the Minnesota nonprofits that need them.

Freecycle <https://www.freecycle.org/>

The Freecycle Network is about reuse and keeping good stuff out of landfills. Membership is free. To sign up, find the community by entering it into the search box above or by clicking on 'Browse Groups' above the search box.

Minnesota Materials Exchange <https://mnexchange.org/>

The Minnesota Materials Exchange is a free service. Operated as part of the Minnesota Technical Assistance Program at the U of MN.

REQUEST FOR VOLUNTEER FORM

Please print clearly

Date Submitted: _____

Requesting Agency Name: _____

Agency Contact Person: _____ Phone: _____

Email: _____ Fax: _____

Event Details

Event Name: _____

Event Location/Address: _____

Event Date(s): _____

Shift Times: _____

(i.e., 8:00am-12:00 or 12:00pm-8:00. Volunteer shifts should not exceed eight hours)

Number of Volunteer(s) per shift: _____

Volunteer Details

Volunteer Position Title: _____

Required Training: _____

Volunteer Responsibilities: _____

(List specific duties) _____

Volunteer Requirements: _____

(List any specific experience required, physical requirements, health considerations, etc.)

Volunteer Special Skills: _____

(Computers, phone systems, language, technical, construction, etc.)

Miscellaneous

Dress code/clothing requirements: _____

Volunteers should bring: _____

(Identification, licenses, certifications, etc.)

Parking Location: _____

Map Attached: yes no

Parking Validation Required: yes no

Parking Permit Required: yes no

Check-In Location: _____

Event Supervisor Name: _____

Volunteer Support: _____

(Food, parking/transportation, supplies, PPE, facilities, communications, etc.)

Action Taken: _____

Note: Requesting agency is required to provide bathroom, hand-washing stations, first-aid, supervision, equipment, and liability insurance for all volunteers assigned to the agency. Plus, complete and return a Volunteer Tracking Log daily to the Volunteer Reception Center Manager.

TEMPLATE related questions:

Please contact the MN HSEM Volunteer Resources Coordinator at
hsem.volunteerresources.dps@state.mn.us

Thank you!!